

**COUNTY OF SAN MATEO  
PLANNING AND BUILDING DEPARTMENT**

**DATE:** June 26, 2024

**TO:** Planning Commission

**FROM:** Steve Monowitz, Director of Planning and Building  
Glen Jia, Project Planner

**SUBJECT:** STAFF REPORT ADDENDUM: Consideration of a Coastal Development Permit, Use Permit, Variance, and Design Review Permit, pursuant to Sections 6328.4, 6500, 6530, and 6565.3, respectively, of the San Mateo County Zoning Regulations, and a Grading Permit, pursuant to Section 9283 of the County Ordinance Code, for the construction of a new 10,178 sq. ft. fire station to replace the existing Fire Station 44, on a 21,695 sq. ft. property located at 501 Stetson Street in the unincorporated Moss Beach area of San Mateo County. A Variance is requested for a reduction in the front setback and an exceedance of the maximum floor area of the zoning district. The project is appealable to the California Coastal Commission. In conjunction with the requested permits, it is recommended that the Planning Commission determine that the project is categorically exempt from California Environmental Quality Act (CEQA) pursuant to CEQA Guidelines Section 15302.

County File Number: PLN 2023-00311 (Coastside Fire Protection District/Duncklee)

**BACKGROUND**

Planning staff distributed the latest project plans and a response letter (Attachment C) to the Midcoast Community Council (MCC) on June 10, 2024. The MCC reviewed the project at their meeting of June 12, 2024. The MCC provided a comment letter (Attachment B) summarizing the issues discussed at the meeting, which included: concerns about the Fire District's rationale for selecting the site; a perception that alternative sites were not adequately analyzed; opposition to the requested zoning variances; opinions that the replacement station has an oversized design and excessive lighting; and assertions that the project may generate new hazards (fire, noise, and air quality) related to the proposed on-site turning radius. In response to these concerns, staff has included further information and analysis in this addendum.

**DISCUSSION**

The project proposes to construct a new fire station to replace the existing Fire Station 44 at 501 Stetson Street in Moss Beach. The project applicant requests a variance for exceptions to the minimum front setback and the maximum building floor area which are necessary to accommodate modern firefighting facilities and equipment and to ensure safe site circulation.

MCC's comments are discussed in detail as follows:

1. *Lack of Alternatives Analysis and Site Selection Rationale*

The MCC requested more information about the site selection rationale and asked Coastside Fire Protection District (CFPD) to consider an alternative location, such as the site proposed for the temporary fire station, to mitigate the impact on the subject neighborhood. In response, the CFPD tasked its staff with investigating the availability of alternative sites.

CFPD concluded that no other options were feasible (see CFPD's response letter, included as Attachment C). CFPD staff also canvassed the community near the subject site and received widespread support for reconstructing the station at its existing location. Additionally, the CFPD staff evaluated the feasibility of relocating the new station to the temporary facility site. This investigation revealed that using the temporary facility site is both impractical and financially infeasible, due to land acquisition costs and extensive project changes that would be required.

2. *Non-Compliance with Zoning Standards*

The MCC is concerned about the project's non-conformity with the development standards relating to size and setback, as set forth in the County Zoning Regulations.

Planning staff identified the non-conformity issue at the early project review stage. However, as discussed in the staff report, a Variance is requested for the proposed front setback reduction and floor area exceedance which are necessary to ensure the full functionality of the fire station and to meet the critical emergency service needs of the area. Throughout the project review process, planning staff worked with the applicant to understand site and facility/operational constraints and to minimize deviations from standard zoning requirements to the extent feasible. Notably, the applicant has significantly reduced the building height to comply with the maximum allowed in the zoning district, thereby minimizing deviation from the zoning development standards. Due to the unique operational demands of fire stations, building and site improvements have been designed to prioritize safe circulation and rapid emergency response.

3. *Oversized Design*

The MCC raised concerns about the alleged oversized design of the proposed fire station, questioning the project's compatibility with the adjoining streets and neighboring residences.

The proposed 2-story fire station is 9,549 sq. ft. in floor area which is significantly larger than neighboring development. In order to ensure full functionality and to accommodate the modern facilities, CFPD explains that the proposed facility size is necessary. Planning staff worked with the CFPD staff to reduce the bulkiness of the building by incorporating a shed roof design at the left wing of the building to soften the overall appearance. Further, as discussed above, the applicant agreed to reduce the building height to mitigate any visual impacts. Additional discussion regarding visual impact can be found in the staff report.

#### 4. Potential New Hazards, including Fire, Noise, and Air Quality

The MCC raised concerns about potential fire hazards and noise and air quality impacts from the new fire station. Potential hazards cited by the MCC are listed below, followed by CFPD's response:

- Diesel fumes that are known to be carcinogenic from the fire truck exhaust, diesel generator and diesel fuel storage and refueling centers. The applicant clarified that the new engine for this station uses a diesel exhaust fluid contamination system, known as clean diesel, which produces lower emissions. The drive-thru return feature will help reduce emissions as well. Engines have lower emissions when idling through a return vs. accelerating back and up into a bay.
- Extremely loud sound from running fire trucks, sirens, and the tones used to send trucks out of the station, will be right next to neighbors in this design. Noise levels from running diesel truck and sirens is about 100 dB to 120 dB, respectively, where an acceptable level of sound for most residential areas are 50-60 decibels. The MCC notes that these high noise levels can cause hearing loss over minutes of exposure. CFPD states that the project proposal includes a return drive, eliminating the need for loud reverse beeps from engines. Additionally, the project includes exhaust fans with inline motors to contain noise within the building, and 15-foot retaining walls significantly reduce sound transmission from trucks, generators, and crew working in the back, which the existing station lacks.

The MCC also identified a potential for a collision with the on-site diesel generator, fueling station, and storage that is proposed to be located next to four homes. Regarding air quality, the MCC states that decontamination area for fire trucks and hazmat materials will take place in the back of the bay which sits right next to homes, where aerosolized particles of contaminants can easily enter open windows.

- Regarding the fueling station/generator, the applicant stated that they have a fuel tank at the back of the station, and the trucks need to be able to drive up next to it to refuel. However, it is not within the return path of travel, and it is protected by bollards. There's no threat of a truck having a collision with the tank. The existing fire station also currently have a tank on site and need to pull trucks up adjacent to it to refuel.
- Regarding the decontamination area, the applicant stated that the room is located inside the apparatus bay for the fire fighters to rinse off after an event. This is common practice and is not different from the current operation.

The MCC suggested relocating the apparatus bay to the northern side of the subject parcel. CFPD states that, due to the shape of the site, if the apparatus bays are relocated to the north side, CFPD would not have the space required to accommodate a return driveway around the back of the station. The return driveway allows for an efficient return to the station without needing to block the street to back-in as CFPS staff currently do. This allows for better visibility, reduces the potential for an accident in front of the station, and gets trucks off the street more efficiently with more preparation time for the next response.

The parcel currently contains a fire station, and the new station is not expected to increase noise levels as operational capacity remains unchanged. Relocating the apparatus bay would offer negligible noise mitigation while significantly impacting project design.

##### 5. Excessive Light

The MCC raised concerns about the potential for excessive lighting and associated health concerns. In response, the applicant submitted two (2) revised lighting plans. The latest lighting plan is included in Attachment A.

According to the applicant, the project proposal aims to harmonize with existing conditions and prevent any disruptive lighting that could affect neighbors and wildlife, while still meeting the essential lighting requirements for safety and functionality. The latest lighting plan revision includes lighting fixtures mounted on retaining walls to prevent and minimize light spillover into neighboring properties. Given the necessity for adequate lighting during emergencies, the design includes pole-mounted lights at the back of the station. These emergency lights would be controlled by a key system and would only be activated during emergencies.

##### 6. Lack of Story Poles

The MCC requested the erection of story poles prior to the June 26, 2024 Planning Commission hearing.

While the County encourages the use of story poles to demonstrate project scale for projects to reviewed by the Coastside Design Review Committee (CDRC), it is not a mandatory requirement. The applicant has provided renderings (Attachment A) to help the community visualize the project's scale and impacts.

Upon the review of the latest project proposal, as discussed in the staff report, staff found that the applicant has addressed the MCC's concerns within the project's constraints, while balancing functionality and impact mitigation. For these reasons, planning staff continues to recommend that the Planning Commission conditionally approve the project at the hearing on June 26, 2024, as detailed by the staff report.

### Attachments

- A. Project Plans
- B. Midcoast Community Council Comment Letter, Dated: June 12, 2024
- C. Response Letter from the Applicant, Date: June 10, 2024



**COUNTY OF SAN MATEO - PLANNING AND BUILDING DEPARTMENT**

# **ATTACHMENT A**

# COASTSIDE FIRE PROTECTION DISTRICT



## FIRE STATION #44

5/22/2024



### CODES & STANDARDS

PARTIAL LIST OF APPLICABLE CODES	
2022 California Administrative Code (CAC)	(Part 1, Title 24, CCR)
2022 California Building Code (CBC)	(Part 2, Title 24, CCR)
(2021 International Building Code Volumes 1 & 2 with 2022 California Amendments)	(Part 2, Title 24, CCR)
2022 California Electrical Code (CEC)	(Part 3, Title 24, CCR)
(2020 National Electrical Code with 2022 California Amendments)	(Part 3, Title 24, CCR)
2022 California Mechanical Code (CMC)	(Part 4, Title 24, CCR)
(2021 IAPMO Uniform Mechanical Code with 2022 California Amendments)	(Part 4, Title 24, CCR)
2022 California Plumbing Code (CPC)	(Part 5, Title 24, CCR)
(2021 IAPMO Uniform Plumbing Code with 2022 California Amendments)	(Part 5, Title 24, CCR)
2022 California Energy Code (CEC)	(Part 6, Title 24, CCR)
2022 California Fire Code (CFC)	(Part 9, Title 24, CCR)
(2021 International Fire Code with 2022 California Amendments)	(Part 9, Title 24, CCR)
2022 California Existing Building Code (CEBC)	(Part 10, Title 24, CCR)
(2021 International Existing Building Code with 2022 California Amendments)	(Part 10, Title 24, CCR)
2022 California Green Building Standards Code (CALGreen)	(Part 11, Title 24, CCR)
2022 California Referenced Standards Code	(Part 12, Title 24, CCR)
Title 19 CCR, Public Safety, State Fire Marshall Regulations	
2019 ASME A17.1/CSA B44-13 Safety Code For Elevators and Escalators (per 2022 CBC Part 2, Ch 35)	
Note: CALIFORNIA Elevator Unit enforces CCR Title 8 and uses the 2004 ASME A17.1 by adoption	
PARTIAL LIST OF APPLICABLE STANDARDS	
NFPA 13 - Standard for the Installation of Sprinkler Systems (as amended) *	(2022 Edition)
NFPA 14 - Standard for the Installation of Standpipe and Hose Systems (as amended) *	(2019 Edition)
NFPA 17 - Standard for Dry Chemical Extinguishing Systems	(2021 Edition)
NFPA 17A - Standard for Wet Chemical Extinguishing Systems	(2021 Edition)
NFPA 20 - Standard for the Installation of Stationary Pumps for Fire Protection	(2019 Edition)
NFPA 22 - Standard for Water Tanks for Private Fire Protection	(2019 Edition)
NFPA 24 - Standard for the Installation of Private Fire Service Mains and Their Appurtenances (as amended) *	(2019 Edition)
NFPA 25 - Standard for the Inspection, Testing, and Maintenance of Water-Based Fire Protection Systems with California Amendments (Based on NFPA 25, 2011 Edition)	(2019 Edition)
NFPA 72 - National Fire Alarm and Signaling Code (as amended) *	(2022 Edition)
NFPA 80 - Fire Doors and Other Opening Protectives	(2019 Edition)
NFPA 92 - Standard for Smoke Control Systems	(2019 Edition)
NFPA 253 - Standard Method of Test for Critical Radiant Flux of Floor Covering Systems Using a Radiant Heat Energy Source	(2019 Edition)
NFPA 2001 - Standard on Clean Agent Fire Extinguishing Systems (as amended) *	(2018 Edition)
ICC 300 - ICC Standard on Seachers, Folding and Telescoping Seating and Grandstands	(2017 Edition)
UL 300 - Standard for Fire Testing of Fire Extinguishing Systems for Protection of Commercial Equipment—with Revisions through December 2014	(2005 (R2010) Edition)
UL 464 - Audible Signal Appliances—with Revisions through October 10, 2003	(2003 Edition)
UL 521 - Heat Detectors for Fire Protective Signaling Systems—with Revisions through July 20, 2005	(1999 Edition)
UL 1971 - Standard for Signaling Devices for the Hearing Impaired	(2018 Edition)

\* See CBC Chapter 35, Referenced Standards for State of California amendments to the NFPA Standards. For a complete list of applicable NFPA standards refer to 2022 CBC (SPM) Chapter 35 and California Fire Code (CFC) Chapter 90.

### T-1 TITLE SHEET

<b>C1.0</b>	<b>COVER</b>
<b>C2.0</b>	<b>TOPOGRAPHIC SURVEY &amp; BOUNDARY RETRACEMENT</b>
<b>C3.0</b>	<b>GRADING PLAN</b>
<b>C4.0</b>	<b>UTILITY PLAN</b>
<b>C5.0</b>	<b>EROSION CONTROL PLAN</b>
<b>C6.0</b>	<b>EROSION CONTROL DETAILS</b>
<b>L1.0</b>	<b>PLANTING PLAN &amp; NOTES</b>
<b>L1.1</b>	<b>PLANTING DETAILS</b>
<b>L2.0</b>	<b>IRRIGATION PLAN &amp; NOTES</b>
<b>L2.1</b>	<b>IRRIGATION DETAILS</b>
<b>L2.2</b>	<b>IRRIGATION DETAILS</b>
<b>A1.1</b>	<b>PROPOSED SITE PLAN &amp; TREE PLAN</b>
<b>A2.1</b>	<b>DIMENSIONED FLOOR PLANS</b>
<b>A4.1</b>	<b>PROPOSED ROOF PLAN</b>
<b>A5.1</b>	<b>PROPOSED EXTERIOR ELEVATIONS</b>
<b>A5.2</b>	<b>PROPOSED EXTERIOR ELEVATIONS</b>
<b>A5.3</b>	<b>PROPOSED BUILDING SECTIONS</b>
<b>E1.1</b>	<b>SITE PLAN</b>
<b>E1.1P</b>	<b>PHOTOMETRIC SITE PLAN</b>



### CONDITIONS OF APPROVAL

**MONTARA WATER & SANITARY DISTRICT**  
 Serving the Communities of Montara and Moss Beach  
 P.O. Box 370131 Tel: (650) 728-3545  
 8888 Cabrillo Highway Fax: (650) 728-8556  
 Montara, CA 94037-0131 E-mail: mwsd@coastside.net  
 Visit Our Web Site: <http://www.mwsd.montara.com>

12/14/2023

#### Recommended Conditions of Approval for PLN2023-00311, APN 037063380, Point Montara Fire, 501 Stetson Street, Moss Beach, CA:

Submit Existing Service Application and pay for the initial application fees based on the remodeling type determined by MWSD. Applicant shall follow the procedures specified in the Existing Service Application Packet.

Video CCTV lower lateral and submit to MWSD (sanitary district) for review. Any defects or pipe that is not to current District code shall be replaced. Current code construction details and additional backflow protection requirements shall apply. Upgrade to 6" lateral is recommended.

15 ft easement width for all MWSD mains is required. The condition of the existing water meter(s), BFP and water lateral connection shall be inspected by MWSD to determine if they are in good working condition; MWSD may require repair or replacement of the existing water meter(s), BFP and water lateral connection. Water meter upgrade may be required.

If connection to the District's fire protection system is required: Certified Fire Protection Contractor must certify adequate fire flow calculations. Connection fee for fire protection system is required. Connection charge must be paid prior to issuance of Private Fire Protection permit.

Applicants must first apply directly to District for permits and not their contractor.

Clemens Heldmaier  
MWSD

### DPW NOTES

1. AUTOMATIC FIRE SPRINKLERS REQUIRED PER NFPA 13.
2. UNDERGROUND FLUSH IS REQUIRED FOR THIS PROJECT. MUST BE WITNESSED BY FIRE DEPARTMENT.
3. SEPARATE PERMITS REQUIRED FOR GENERATOR, FIRE ALARM, AND FIRE SPRINKLERS.

### GOVERNING AGENCIES

COUNTY OF SAN MATEO  
 PLANNING AND BUILDING DEPARTMENT  
 400 COUNTY CENTER  
 REDWOOD CITY, CA 94063  
 (650) 363-4000

### PROJECT DATA

PROJECT ADDRESS:	501 STETSON ST. MOSS BEACH, CA 94038	LOT COVERAGE: MAX. ALLOWED: 35% PROPOSED: 7,025 SF (BLDG. FOOTPRINT) / 21,695 (SITE AREA) = 32.4 % 32.4% < 35% OK
ASSESSOR'S PARCEL NO.:	037 063 380	FLOOR AREA RATIO: MAX. ALLOWED: 6,200 SF (PER S-17 ZONE) PROPOSED: 10,178 SF (SEE A2.1 FOR FLOOR AREA CALCULATION) FLOOR AREA RATIO = 10,178 SF / 21,695 SF = 0.47
ZONING:	R-1/S-17/DR/CD	BUILDING HEIGHT: MAX. ALLOWED: 28 FEET TYP. PROPOSED: 28'-0"
GOVERNING CODES:	2022 CBC	SQUARE FOOTAGE OF LANDSCAPING: NEW: 3,914 SF REHABILITATED: 0 SF
OCCUPANCY GROUP:	R-2 / S-2 / B	
CONSTRUCTION TYPE:	V-B	
TOTAL BUILDING AREA:	10,178 SF	
TOTAL SITE AREA:	21,695 SF	
NUMBER OF STORIES:	2	
PARKING:		
ACCESSIBLE:	1	
STANDARD PUBLIC:	1	
STAFF:	7	
TOTAL:	9	

### PROJECT TEAM

<b>OWNER</b>  COASTSIDE FIRE PROTECTION DISTRICT 555 OBISPO RD. HALF MOON BAY, CA 94018 650-726-5213 PH	<b>ARCHITECT</b>  PBK 1327 ARCHER STREET SUITE 110 SAN LUIS OBISPO, CA 93401 805-329-3076 PH
<b>CIVIL ENGINEER</b>  MCR ENGINEERING 1322 DUPONT CT. MANTECA, CA 95336 209-239-6229 PH	<b>ELECTRICAL ENGINEER</b>  A & F ENGINEERING GROUP INC. 9320 BASELINE ROAD, SUITE C RANCHO CUCAMONGA, CA 91701 909-941-3008 PH
<b>GEOTECHNICAL ENGINEER</b>  GEOCON CONSULTANTS, INC. 8671 BRISA STREET LIVERMORE, CA 94550 925-371-5900 PH	<b>LANDSCAPE ARCHITECT</b>  WDSLA 150 MISSION ST SAN FRANCISCO, CA 94102 916-907-2942 PH

### VICINITY MAP



Not for permitting or construction

ARCHITECT PBK Architects, Inc.  
SAN LUIS OBISPO  
1327 Archer Street, Suite 110  
San Luis Obispo, CA 93401  
805-329-3076

FIRE STATION #44  
COASTSIDE FIRE PROTECTION DISTRICT  
501 STETSON STREET  
MOSS BEACH, CA 94038  
PLANNING SUBMITTAL

G	H	J
D	E	F
A	B	C

KEY PLAN

PLAN TRUE NORTH

CLIENT		
COASTSIDE FIRE PROTECTION DISTRICT		
PROJECT NUMBER		
DATE	5/22/2024	
DRAWN BY:	KF/OS CHKED BY: AD	
REVISIONS		
#	DESCRIPTION	DATE

PLANNING SUBMITTAL

TITLE SHEET

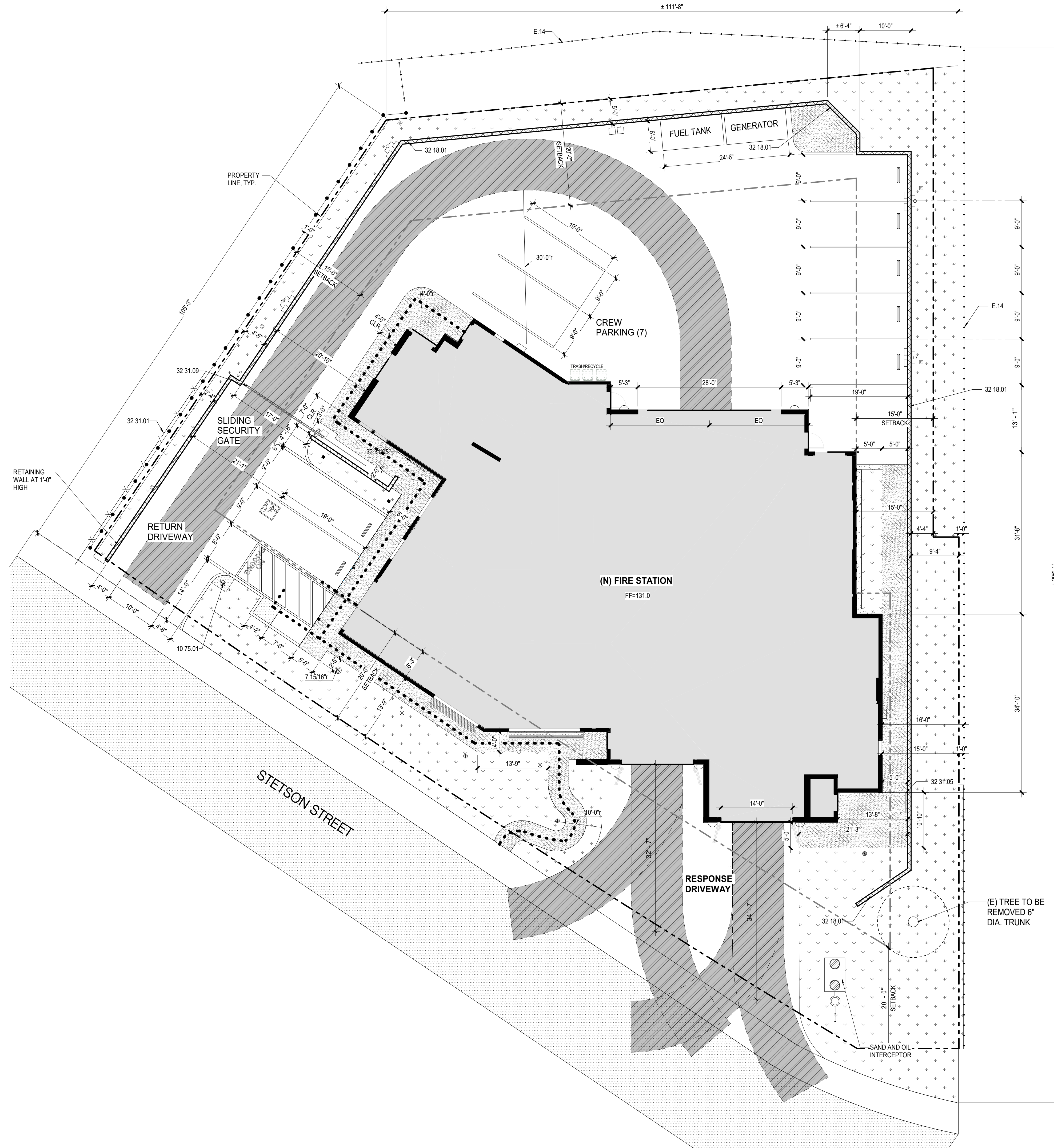

**KEYNOTE LEGEND**

10 75.01	FLAGPOLE
32 18.01	RETAINING WALL VARIES IN HEIGHT. SEE CIVIL DRAWINGS
32 31.01	(N) WOOD FENCING
32 31.05	METAL FENCE GATE
32 31.09	SLIDING SECURITY GATE
E.14	(E) WOOD FENCE TO REMAIN

**PBK**  
 ARCHITECT PBK Architects, Inc.  
 SAN LUIS OBISPO  
 1327 Archer Street, Suite 110  
 San Luis Obispo, CA 93401  
 805-328-3076

**FIRE STATION #44**  
 COASTSIDE FIRE PROTECTION DISTRICT  
 501 STETSON STREET  
 MOSS BEACH, CA 94038  
 PLANNING SUBMITTAL

**KEY PLAN**

G	H	J
D	E	F
A	B	C

PLAN NORTH TRUE NORTH

LICENSED ARCHITECT  
 AUSTIN DUNCLEE  
 C-30729  
 REN. 06-30-23  
 STATE OF CALIFORNIA

CLIENT: COASTSIDE FIRE PROTECTION DISTRICT  
 PROJECT NUMBER: 230137  
 DATE: 5/22/2024  
 DRAWN BY: KF/OS CHKED BY: AD

#	REVISIONS DESCRIPTION	DATE

PLANNING SUBMITTAL

**PROPOSED SITE PLAN & TREE PLAN**

**SITE PLAN NOTES**

- REFER TO CIVIL DOCUMENTS FOR GRADING & UTILITY INFORMATION. SEE SHEET 02.0.
- COORD. ALL SPOT ELEVATIONS AND DIMENSIONS WITH CIVIL, LANDSCAPE, AND/OR STRUCTURAL DOCUMENTS.
- PROVIDE AND INSTALL POSITIVE DRAINAGE AWAY FROM ALL BUILDINGS OF 1% MINIMUM, 2% MAXIMUM AT ALL EXTERIOR PAVED PEDESTRIAN AREAS, INCLUDING BUT NOT LIMITED TO, SIDEWALKS, PATIOS, STAIRS, PAVING, U.N.O.
- PROVIDE AND INSTALL POSITIVE DRAINAGE AWAY FROM ALL BUILDINGS OF 3% FOR A HORIZ. DISTANCE OF 10 FEET AT ALL EXTERIOR NON-PAVED AREAS U.N.O.
- REFER TO CIVIL DOCUMENTS FOR CONCRETE SIDEWALK EXPANSION JOINTS AND CONCRETE SIDEWALK CONTROL JOINTS.
- VERIFY AND CONFIRM ALL JOINT LAYOUTS AT ALL CONCRETE SIDEWALKS (WITH AFCH, PRIOR TO POURING OF CONCRETE).
- PROVIDE AND INSTALL CONCRETE SIDEWALK EXPANSION JOINTS AT AREAS NOT SPECIFICALLY INDICATED AT 50 FEET ON-CENTER MAX. U.N.O.
- PROVIDE AND INSTALL CONCRETE SIDEWALK CONTROL JOINTS AT AREAS NOT SPECIFICALLY INDICATED AT DISTANCES EQUIVALENT TO SIDEWALK WIDTH, BUT NOT TO EXCEED 10 FEET ON-CENTER MAX.
- VERIFY ALL SITE SIGNAGE LOCATIONS WITH ARCH. PRIOR TO INSTALLATION OF SITE SIGNAGE.

	CONCRETE PAVING		(E) FIRE HYDRANT
	LANDSCAPED AREA		PROPOSED FIRE HYDRANT RE. CIVIL
	PROPOSED BUILDING		FIRE DEPARTMENT CONNECTION
	PROPOSED FIRE ACCESS LANE		BUILDING ID SIGN
	8' CMU RETAINING WALL		8' CMU WALL
	PROPERTY LINE		PROPOSED (N) WOOD LINK FENCE
	ACCESSIBLE PATH OF TRAVEL		6'-0" (E) HIGH WOOD FENCE

**LEGEND - SITE PLAN**  
 SCALE: 1/4" = 1'-0"



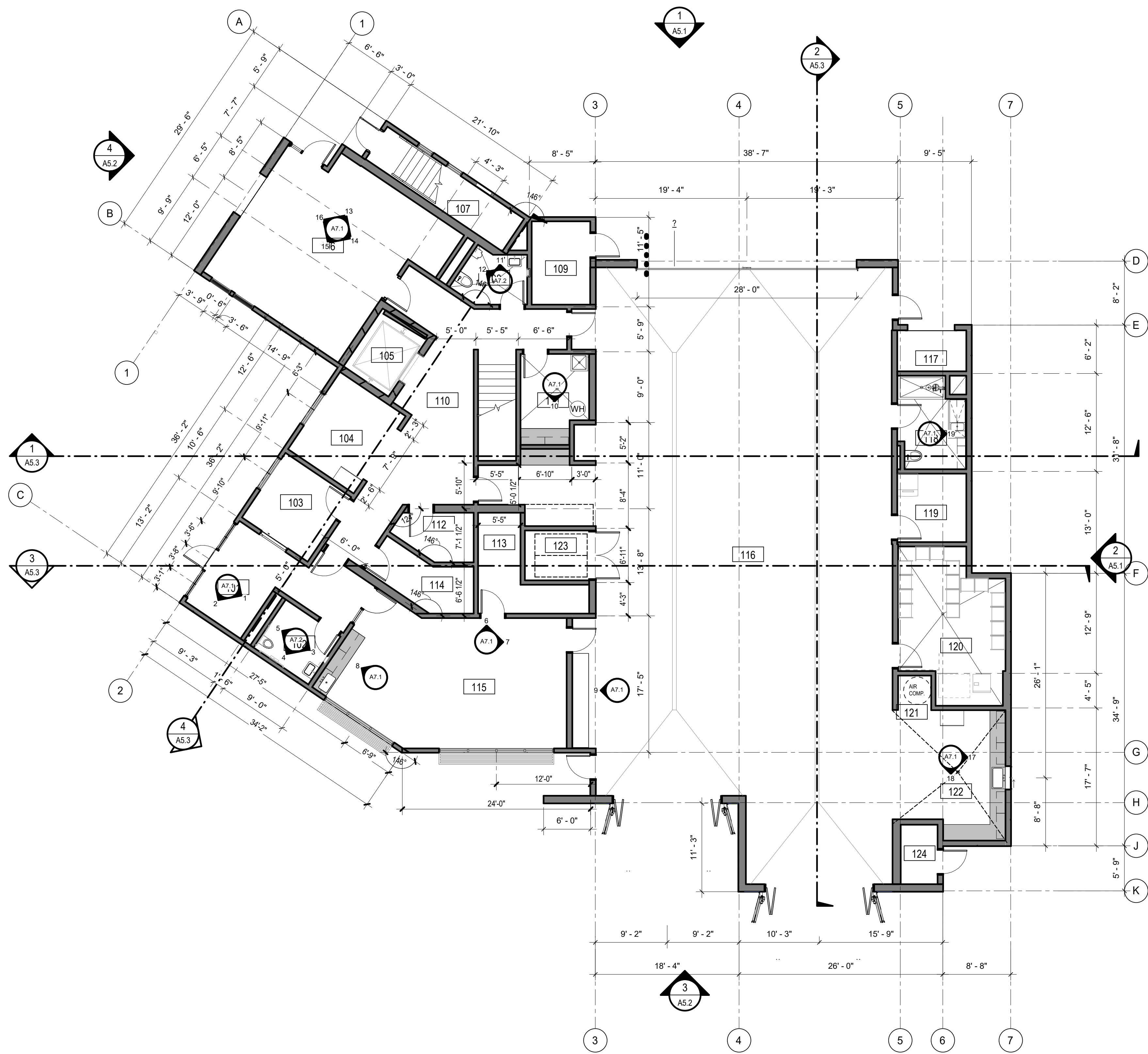

FIRST FLOOR GROSS AREA = 6,612 SF

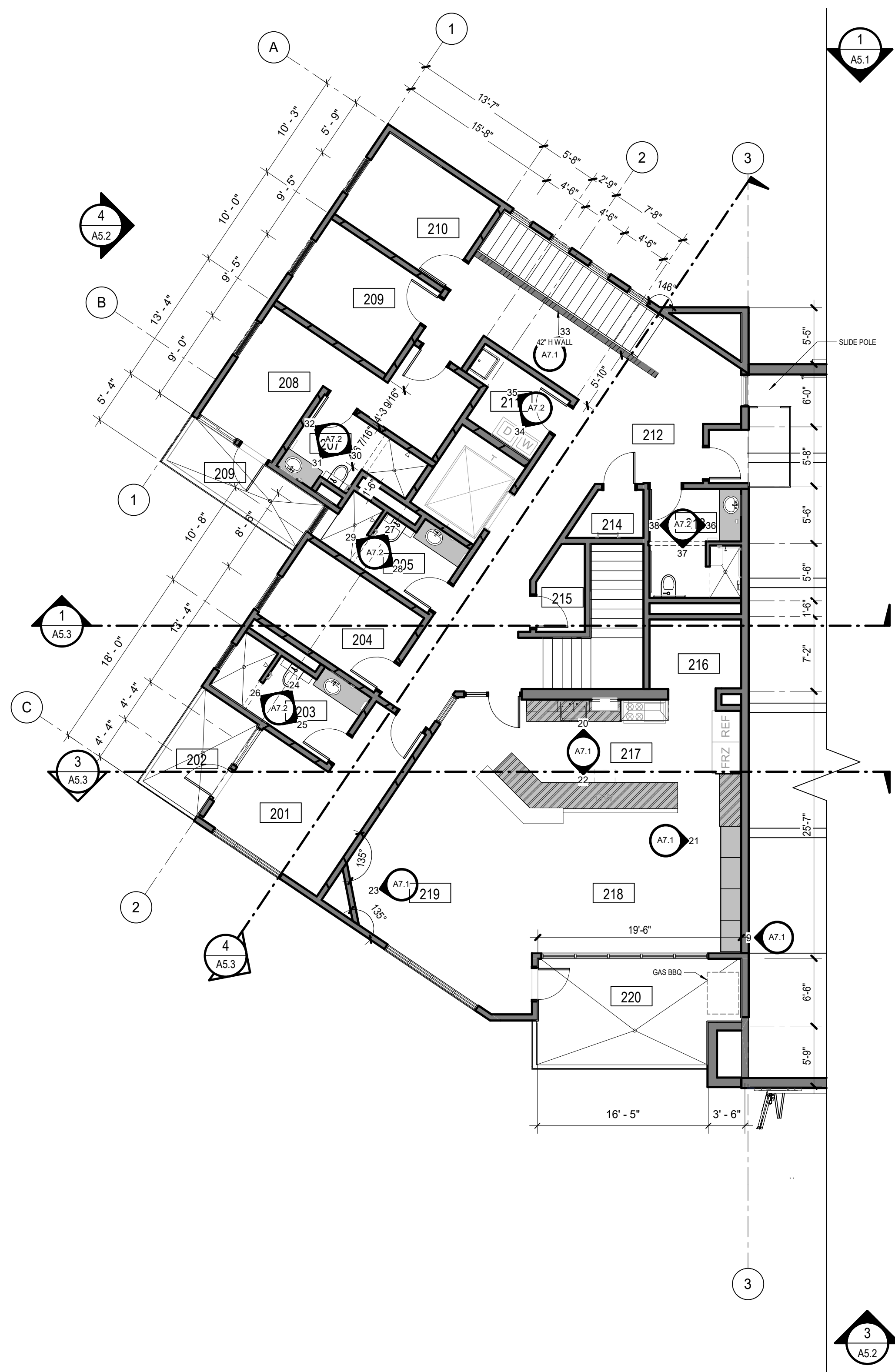

SECOND FLOOR GROSS AREA = 3,566 SF

**1** FP01 - FIRST FLOOR DIMENSION PLAN  
 SCALE: 1/8" = 1'-0"

ROOM SCHEDULE FIRST FLOOR			ROOM SCHEDULE FIRST FLOOR			ROOM SCHEDULE SECOND FLOOR		
Name	Number	Area	Name	Number	Area	Name	Number	Area
LOBBY	101	174 SF	SHOP	122	222 SF	BAT. CHIEF	201	186 SF
RR 1	102	62 SF	HOSE DRY STOR	123	52 SF	BALCONY	202	66 SF
CAPT. OFFICE	103	100 SF	FR	124	36 SF	BC RR	203	91 SF
OFFICE	104	124 SF				DORM 1	204	116 SF
ELEV	105	59 SF				RR	205	84 SF
FITNESS	106	476 SF				ELEV	206	66 SF
STAIRWAY 1	107	105 SF				RR 3	207	73 SF
RR	108	56 SF				CAPTAIN	208	185 SF
ELECT	109	79 SF				DORM 2	209	120 SF
HALLWAY	110	375 SF				BALCONY	209	73 SF
CUST	111	94 SF				DORM 3	210	120 SF
EL MACH	112	55 SF				LAUNDRY	211	59 SF
STOR	113	102 SF				HALLWAY	212	559 SF
TELECOM	114	77 SF				ACCESSIBLE RR	213	91 SF
TRAINING CLASSROOM	115	483 SF				VEST	214	27 SF
APPARATUS BAY	116	2,954 SF				STOR 3	215	35 SF
YARD ST	117	46 SF				PANTRY	216	61 SF
DECON	118	94 SF				KITCHEN	217	302 SF
EMS STOR	119	77 SF				DINING	218	215 SF
TURNOUT	120	235 SF				DAYROOM	219	347 SF
COMP	121	19 SF				DECK	220	185 SF

**2** FP02 - SECOND FLOOR DIMENSION PLAN  
 SCALE: 1/8" = 1'-0"

KEYNOTE LEGEND	FLOOR PLAN LEGEND	GENERAL FLOOR PLAN NOTES
<p>KEYNOTE LEGEND</p>	<p>FLOOR PLAN LEGEND</p> <p>ROOM NAME: ROOM NAME &amp; NUMBER</p> <p>NEW PARTITION</p> <p>PARTITION TYPE: REFER TO SHEET AT-00 FOR DEFINITION</p> <p>1 HR FIRE RATING</p> <p>42" HIGH WALL</p> <p>DOOR DESIGNATION</p> <p>WINDOW DESIGNATION</p> <p>STAINLESS STEEL COUNTERTOPS</p>	<p>GENERAL FLOOR PLAN NOTES</p> <ol style="list-style-type: none"> <li>DO NOT SCALE DRAWINGS. WRITTEN DIMENSIONS TAKE PRECEDENCE. CONTACT ARCH IF CLARIFICATION IS NECESSARY IN ORDER TO DETERMINE THE INTENT OF THE CONTRACT DOCUMENTS.</li> <li>DRAWINGS NOTED AS "N.T.S." OR "N.T.S." ARE NOT TO SCALE.</li> <li>ALL DIMENSIONS ARE TO STRUCTURAL COLUMN LINES OR THE SURFACE OF PARTITION ASSEMBLY U.N.O.</li> <li>FIELD VERIFY ALL DIMENSIONS AND EXISTING CONDITION BEFORE COMMENCING WORK. NOTIFY ARCH. OF ANY DISCREPANCIES PRIOR TO PROCEEDING WITH AFFECTED WORK.</li> <li>NOTES OR DIMENSIONS NOTED AS "TYPICAL" OR "TYP." OR "TYP" SHALL APPLY TO CONDITIONS THAT ARE THE SAME OR SIMILAR.</li> <li>DIMENSIONS NOTED AS "FIELD VERIFY" OR "V.I.F." OR "V.I.F." SHALL BE MEASURED AND CONFIRMED AT THE PROJECT SITE BY THE CONTRACTOR AND REVIEWED WITH THE ARCH. BEFORE INCORPORATING INTO THE WORK.</li> <li>DIMENSIONS NOTED AS "CLEAR" OR "CLEAR INSIDE" REQUIRE SPECIFIC COORDINATION AMONG DISCIPLINES AND/OR MANUFACTURERS.</li> <li>REFER TO PARTITION TYPES ON AT-00 SERIES SHEETS.</li> <li>ALL INTERIOR PARTITIONS THIS SHEET, EXCEPT FOR FURR-OUT PARTITIONS, SHALL BE PARTITION TYPE U.N.O.</li> <li>ALL INTERIOR FURR-OUT PARTITIONS THIS SHEET SHALL BE PARTITION TYPE U.N.O. OR ADJOIN IN THE SAME PLANE.</li> <li>ALL DOORS SHALL BE SET 6 INCHES OFF THE ADJACENT PERPENDICULAR WALL ON THE HINGE SIDE OF THE DOOR U.N.O., NOTIFY ARCH. OF ANY DOOR-RELATED CONFLICTS, INCLUDING BUT NOT LIMITED TO CONFLICTS CONCERNING ACCESSIBILITY STANDARDS.</li> <li>ALL DOOR THRESHOLDS AT ALL EXTERIOR DOORS SHALL BE SET IN FULL BED OF SEALANT.</li> <li>COORD. ALL ROOF DRAIN LEADER LOCATIONS WITH FLOOR PLAN PRIOR TO FLOOR SLAB CONSTRUCTION.</li> <li>ALL FLOOR SLOPES TO FLOOR DRAINS SHALL NOT EXCEED 1/48.</li> <li>PROVIDE AND INSTALL SELF-LEVELING UNDERLAYMENT WHERE UNEVEN FLOOR SLAB EXISTS PRIOR TO INSTALLATION OF FLOOR FINISHES.</li> <li>COORD. HOUSEKEEPING PAD LOCATIONS AND DIMENSIONS WITH EQUIPMENT TO BE INSTALLED.</li> <li>ALL FLOOR FINISH CHANGES SHALL OCCUR AT THE CENTERLINE OF DOORS U.N.O.</li> <li>ALL FLOOR FINISH MATERIAL CHANGES SHALL HAVE REDUCER STRIPS.</li> <li>ALL REQUIRED ACCESSIBLE CLEARANCES FOR ALL ITEMS, INCLUDING BUT NOT LIMITED TO ALL COUNTER TOPS, ALL PLUMBING FIXTURES, ALL DRINKING FOUNTAINS, ALL ELECTRIC WATER COOLERS, ALL LAVATORIES, ALL URINALS, ALL TOILETS SHALL BE STRICTLY ENFORCED.</li> <li>REFER TO OTHER DISCIPLINE DOCUMENTS FOR ADDITIONAL SCOPE OF WORK.</li> </ol>

PLANNING SUBMITTAL

**FIRE STATION #44**  
 COASTSIDE FIRE PROTECTION DISTRICT  
 501 STETSON STREET  
 MOSS BEACH, CA 94038  
 PLANNING SUBMITTAL



G	H	J
D	E	F
A	B	C

KEY PLAN  
 PLAN NORTH  
 TRUE NORTH

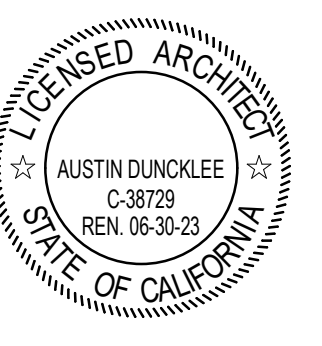

REVISIONS		
#	DESCRIPTION	DATE

CLIENT: COASTSIDE FIRE PROTECTION DISTRICT  
 PROJECT NUMBER: 230137  
 DATE: 5/22/2024  
 DRAWN BY: KF/OS  
 CHECKED BY: AD

**DIMENSIONED FLOOR PLANS**

**A2.1**

**1** ROOF PLAN  
SCALE: 1/8" = 1'-0"

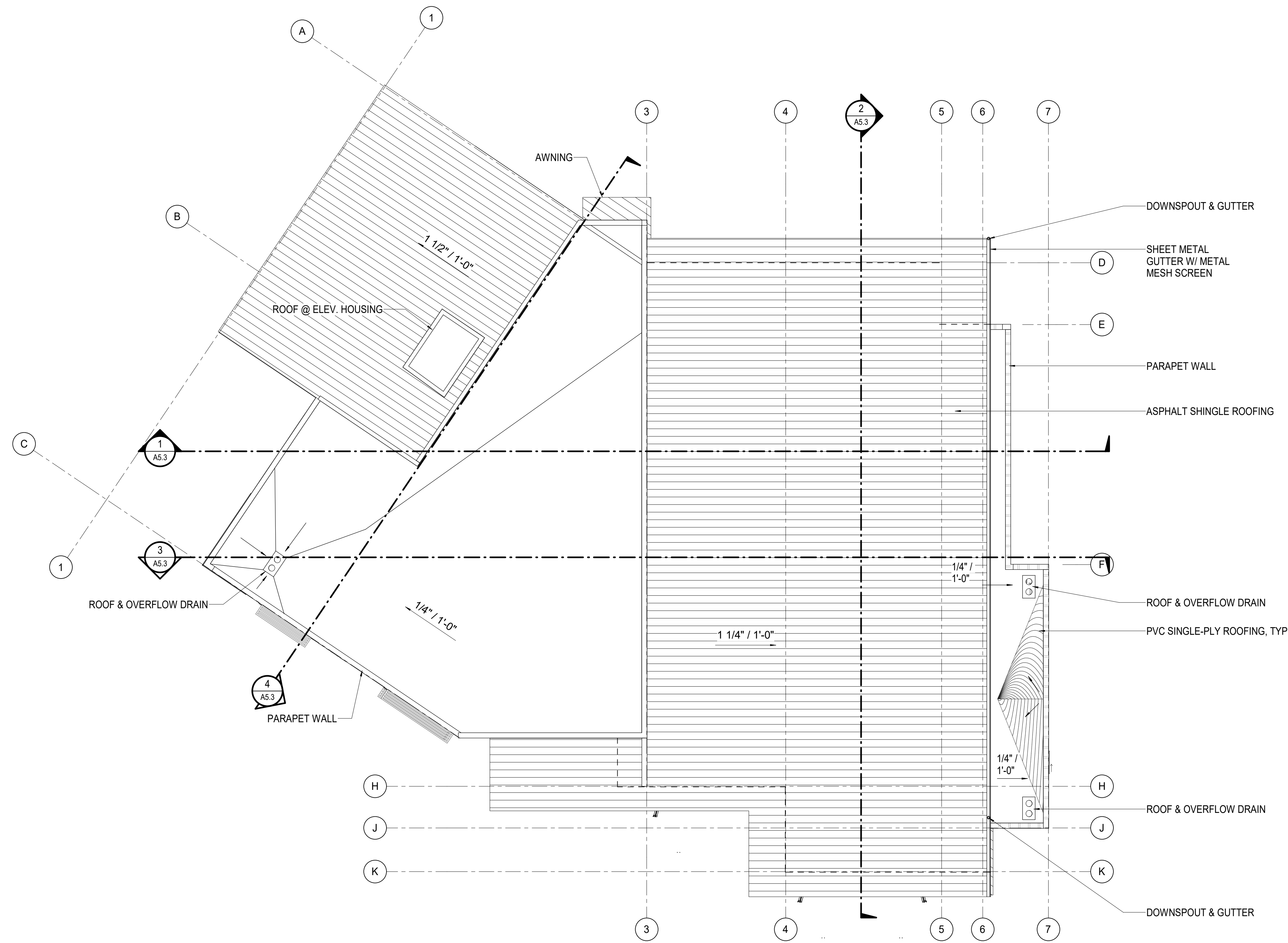

ROOF PLAN LEGEND

KEYNOTE LEGEND

GENERAL NOTES

- ROOF PLAN NOTES:
1. ALL HEIGHTS ARE REFERENCED FROM FINISH FLOOR ELEVATION = 0'-0". REFER TO PLANS AND SECTIONS FOR ADDITIONAL INFORMATION.
  2. FOR ADDITIONAL CONDUIT AND PIPING PENETRATIONS AT ROOF AREAS, SEE MECHANICAL, PLUMBING, AND ELECTRICAL DRAWINGS. FOR DETAIL AT METAL STUD FRAMED AREAS, SEE DETAILS 5 AND 6.
  3. SEE DETAIL FOR ROOF TOP EQUIPMENT CRICKET.
  4. SEE DETAIL FOR FLASHING AT INTERSECTING WALLS.
  5. PROVIDE MINIMUM 1/2" PER FOOT ROOF SLOPE FOR DRAINAGE AT ALL FLAT ROOF LOCATIONS.
  6. PROVIDE SPLASH BLOCK FOR GUTTER DOWNSPOUTS TERMINATING AT FLAT ROOF. SEE DETAIL.



ARCHITECT PBK Architects, Inc.  
 SAN LUIS OBISPO  
 1327 Archer Street, Suite 110  
 San Luis Obispo, CA 93401  
 805-328-3076

**FIRE STATION #44**  
 COASTSIDE FIRE PROTECTION DISTRICT

501 STETSON STREET  
 MOSS BEACH, CA 94038



G	H	J
D	E	F
A	B	C

KEY PLAN  
 PLAN NORTH  
 TRUE NORTH

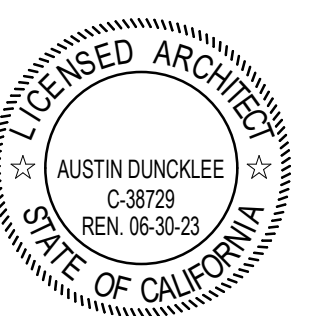

CLIENT	
COASTSIDE FIRE PROTECTION DISTRICT	
PROJECT NUMBER	
230137	
DATE	4/10/2024
DRAWN BY:	KF/OS
CHECKED BY:	AD
REVISIONS	
#	DESCRIPTION

PLANNING SUBMITTAL  
**PROPOSED ROOF PLAN**

PLANNING SUBMITTAL

Not for permitting or construction  
This document is for plan review only



G	H	J
D	E	F
A	B	C

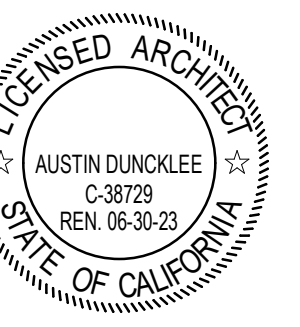
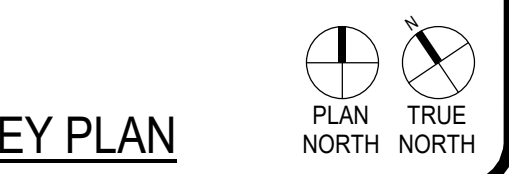

CLIENT	COASTSIDE FIRE PROTECTION DISTRICT	
PROJECT NUMBER	230137	
DATE	4/10/2024	
DRAWN BY:	KF/OS	
CHECKED BY:	AD	
REVISIONS		
#	DESCRIPTION	DATE

PLANNING SUBMITTAL

**PROPOSED EXTERIOR ELEVATIONS**

Not for permitting or construction

PLANNING SUBMITTAL

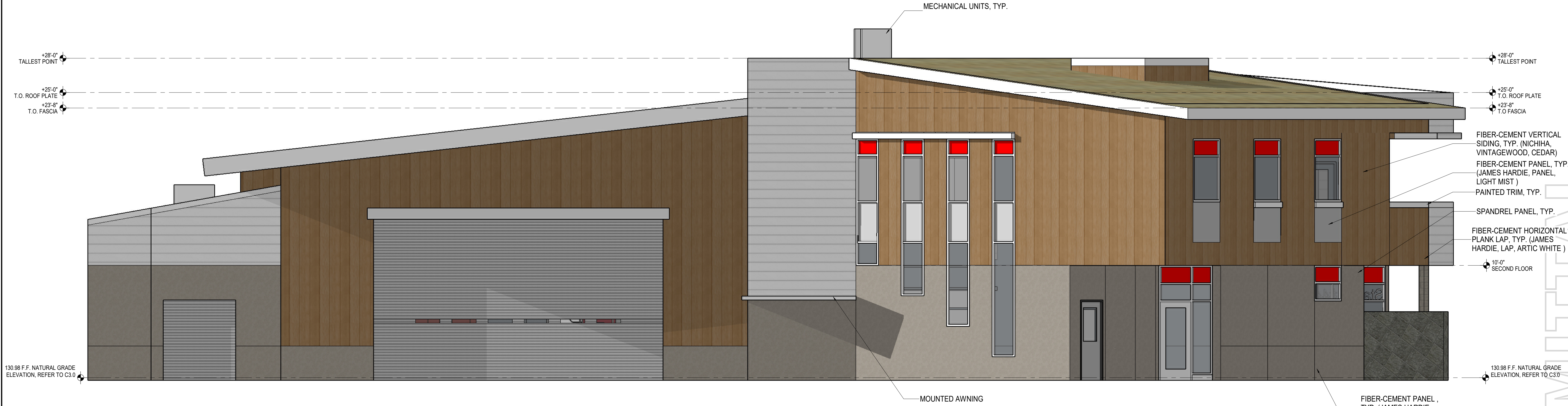

**1** EXTERIOR ELEVATION - NORTH  
 SCALE: 1/4" = 1'-0"

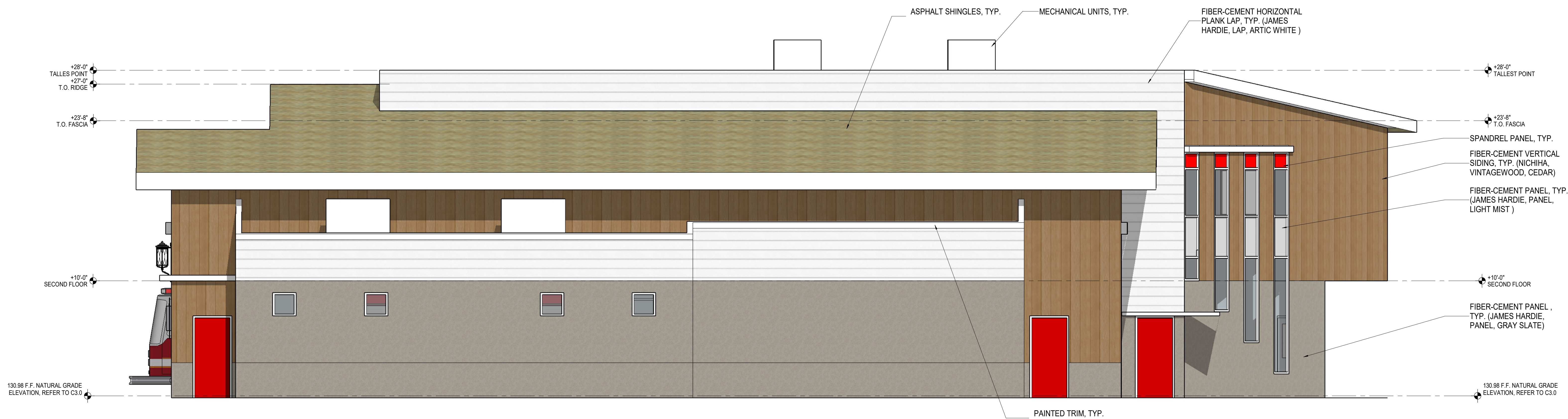

**2** EXTERIOR ELEVATION - EAST  
 SCALE: 1/4" = 1'-0"



G	H	J
D	E	F
A	B	C

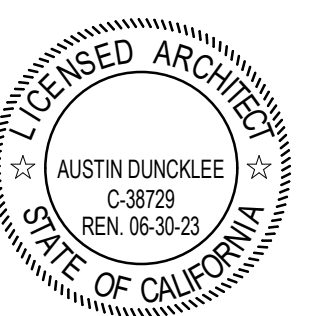

CLIENT COASTSIDE FIRE PROTECTION DISTRICT		
PROJECT NUMBER 230137		
DATE 4/10/2024		
DRAWN BY: KF/OS    CHECKED BY: AD		
REVISIONS		
#	DESCRIPTION	DATE

PLANNING SUBMITTAL  
**PROPOSED EXTERIOR ELEVATIONS**

This document is for plan review only

PLANNING SUBMITTAL



**3** EXTERIOR ELEVATION - SOUTH  
SCALE: 1/4" = 1'-0"



**4** EXTERIOR ELEVATION - WEST  
SCALE: 1/4" = 1'-0"



G	H	J
D	E	F
A	B	C

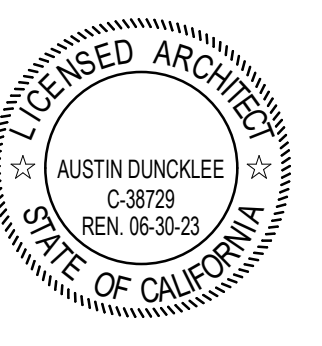

CLIENT	COASTSIDE FIRE PROTECTION DISTRICT	
PROJECT NUMBER	230137	
DATE	4/10/2024	
DRAWN BY:	KF/OS	
CHECKED BY:	AD	
REVISIONS		
#	DESCRIPTION	DATE

PLANNING SUBMITTAL  
**PROPOSED BUILDING SECTIONS**

Not for permitting or construction  
 This document is for plan review only

PLANNING SUBMITTAL

ROOM SCHEDULE FIRST FLOOR - SECTION	
Name	Number
LOBBY	101
RR 1	102
CAPT. OFFICE	103
OFFICE	104
ELEV	105
FITNESS	106
STAIRWAY 1	107
RR	108
ELECT	109
HALLWAY	110
CUST	111
EL MACH	112
STOR	113
TELECOM	114
TRAINING CLASSROOM	115
APPARATUS BAY	116
YARD ST	117
DECON	118
EMS STOR	119
TURNOUT	120
COMP	121
SHOP	122
HOSE DRY STOR	123
FR	124

ROOM SCHEDULE SECOND FLOOR - SECTION	
Name	Number
BAT. CHIEF	201
BALCONY	202
BC RR	203
DORM 1	204
RR	205
ELEV	206
RR 3	207
CAPTAIN	208
DORM 2	209
BALCONY	209
DORM 3	210
LAUNDRY	211
HALLWAY	212
ACCESSIBLE RR	213
VEST	214
STOR 3	215
PANTRY	216
KITCHEN	217
DINING	218
DAYROOM	219
DECK	220

**GENERAL NOTES**

- ALL EXTERIOR AND ROOF ASSEMBLIES ARE INSULATED.
- PROVIDE R-19 INSULATION AT WALLS.
- PROVIDE SOLID BACKING IN WALL AT ALL LOCATIONS OF WALL MOUNTED ITEMS.
- REFER TO FINISH SCHEDULE A7.02-2 FOR ADDITIONAL FINISH INFO.
- SECOND FLOOR 1-HR RATING PER U.L. DES D216. SEE A8.20-2 FOR FLOOR-CEILING ASSEMBLY, AND PENETRATION FIRESTOPPING THROUGH FLOOR.

**MATERIALS LEGEND**

	1-HR FIRE RATED ASSEMBLY
	MS-1 EXTERIOR METAL SIDING 1
	MS-2 EXTERIOR METAL SIDING 2 REGAL RED
	MS-3 EXTERIOR METAL SIDING 3 SANDSTONE
	MS-4 EXTERIOR METAL SIDING 4 BLACK
	MS-5 EXTERIOR METAL SIDING 5 ASH GRAY
	FRP-3 FIBERGLASS REINFORCED PANEL
	TB-1 TACKABLE WALL SURFACE
	RB-1 RUBBER BASE

**KEYNOTE LEGEND**

**INSULATION SCHEDULE**

1. R-30:	AT ALL ROOF (RIGID INSULATION)
2. R-21:	AT ALL EXTERIOR WALLS AND ALL APPARATUS ROOM WALLS
3. R-19:	ACOUSTICAL BATT INSULATION AT ALL OTHER INTERIOR 6" WALLS

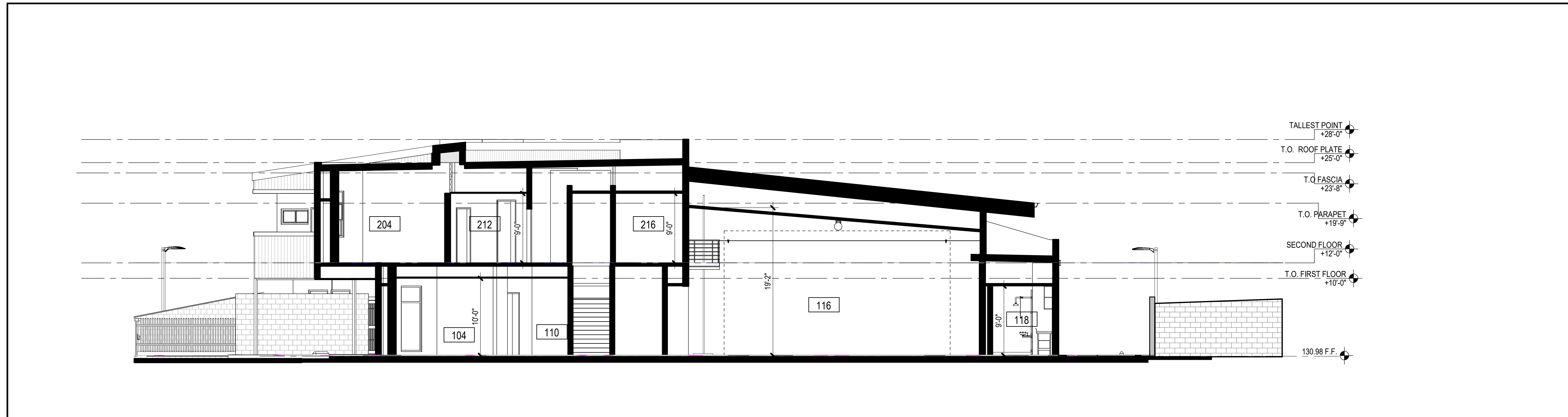

**1 BUILDING SECTION 1**  
 SCALE: 1/8" = 1'-0"

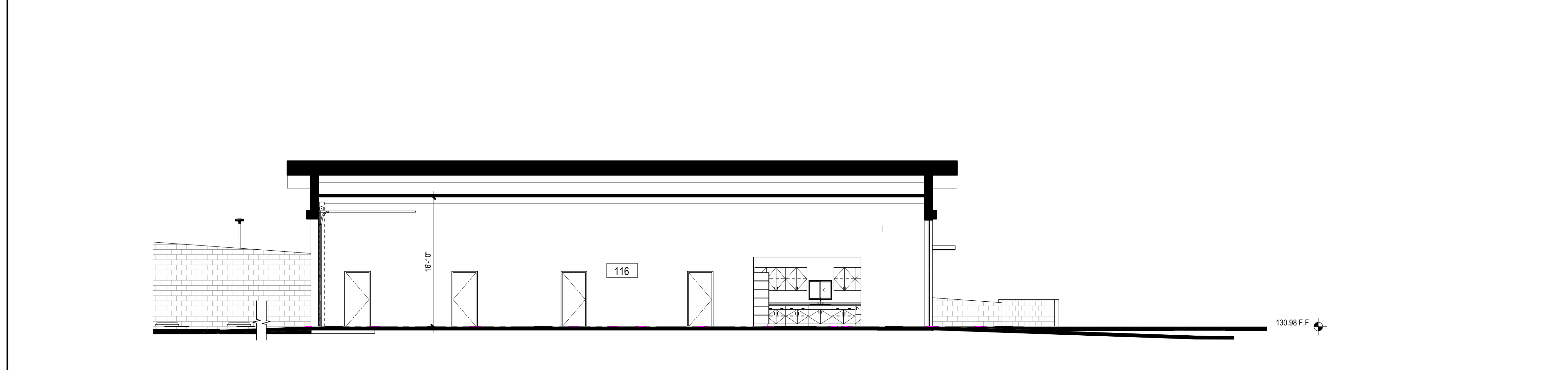

**2 BUILDING SECTION 2**  
 SCALE: 1/8" = 1'-0"

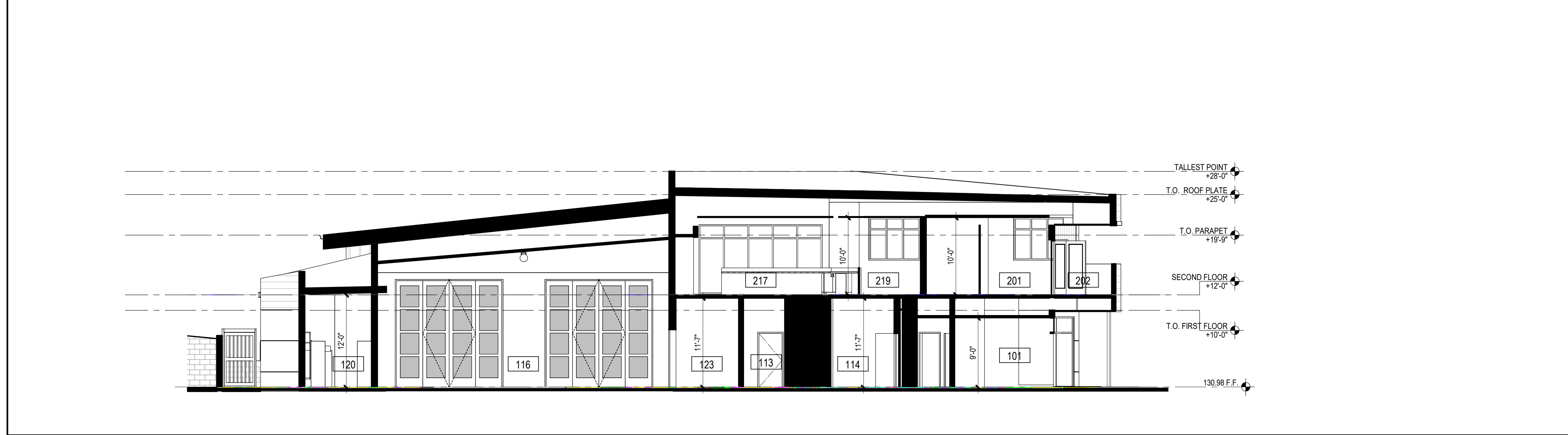

**3 BUILDING SECTION 3**  
 SCALE: 1/8" = 1'-0"

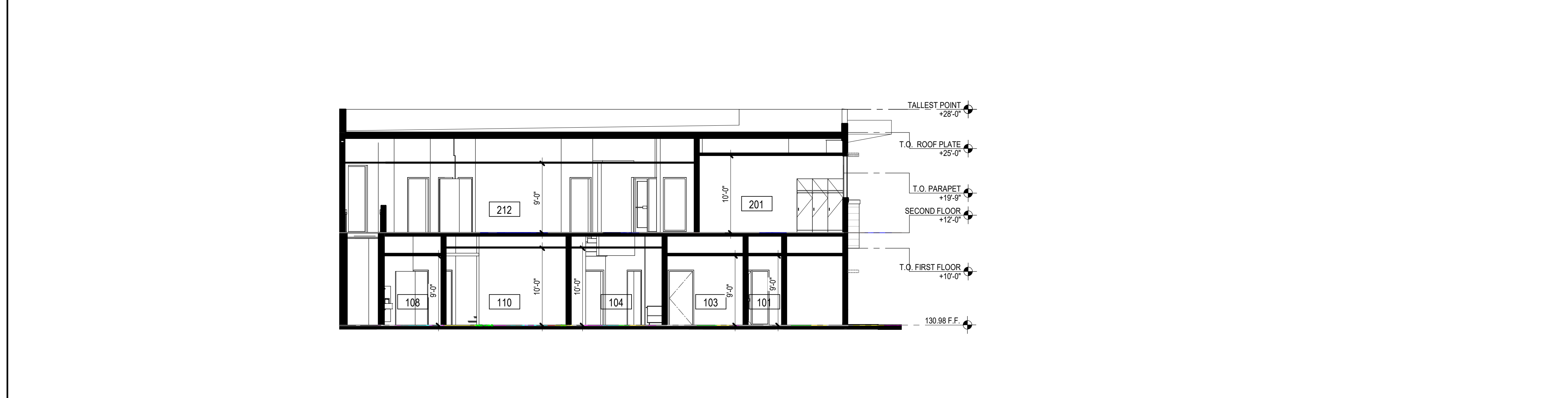

**4 BUILDING SECTION 4**  
 SCALE: 1/8" = 1'-0"

**PLAN NOTES**

① THIS LIGHTING PATTERN REPRESENTS ILLUMINATION LEVELS CALCULATED FROM LABORATORY DATA TAKEN UNDER CONTROLLED CONDITIONS UTILIZING CURRENT INDUSTRY STANDARD LAMP RATINGS IN ACCORDANCE WITH ILLUMINATING ENGINEERING SOCIETY APPROVED METHODS. ACTUAL PERFORMANCE OF ANY MANUFACTURER'S LUMINAIRE MAY VARY DUE TO VARIATION IN ELECTRICAL VOLTAGE, TOLERANCE IN LAMPS AND OTHER VARIABLE FIELD CONDITIONS.

**Statistics**

Description	Symbol	Avg	Max	Min	Max/Min	Avg/Min
Back Drive	+	3.7 fc	14.4 fc	1.0 fc	14.4:1	3.7:1
Front Property Line	+	0.0 fc	0.0 fc	0.0 fc	N/A	N/A
Front Drive	+	2.0 fc	18.0 fc	0.0 fc	N/A	N/A
Front Walkway	+	10.2 fc	20.8 fc	0.0 fc	N/A	N/A
Left Drive	+	3.8 fc	62.7 fc	0.0 fc	N/A	N/A
Left Walkway	+	4.4 fc	15.9 fc	0.1 fc	15.9:0.1	44:0.1
Right Walkway	+	5.8 fc	15.9 fc	0.3 fc	53:0.1	19.3:1

**SITE LIGHTING FIXTURE SCHEDULE**

TYPE	MANUFACTURER/ MODEL	LAMP/ TEMP	WATTS/ VOLTAGE	MOUNTING HEIGHT
Ⓐ	LITHONIA LIGHTING *UPX1-LED-P2-30K-MVOLT-DBLXD	LED 3000K	24W	AS NOTED
Ⓑ	U.S. ARCHITECTURAL LIGHTING *RFP2-160L-35-3K8-4F-UNV-?-N/A/S	LED 3000K	38W	10'-0"
Ⓒ	GOTTLUM LIGHTING *EV0650RH-3019-OFF-90L-120-EZI-NLT	LED 3000K	15W	
Ⓓ	U.S. ARCHITECTURAL LIGHTING *NA-LED-AS7-24LED-WU-120-?-DIM	LED 3000K	28W	

PLANNING SUBMITTAL

FIRE STATION #44  
 COASTSIDE FIRE PROTECTION DISTRICT



801 STETSON STREET  
 MOSS BEACH, CA 94038  
 PLANNING SUBMITTAL

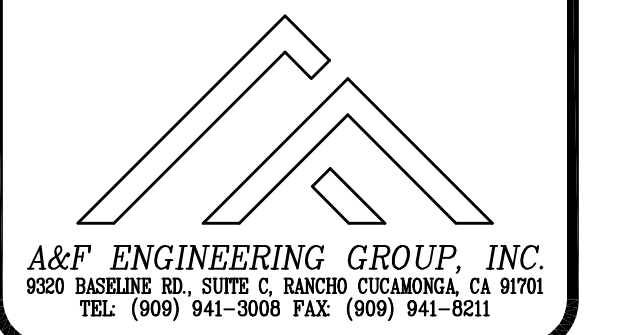
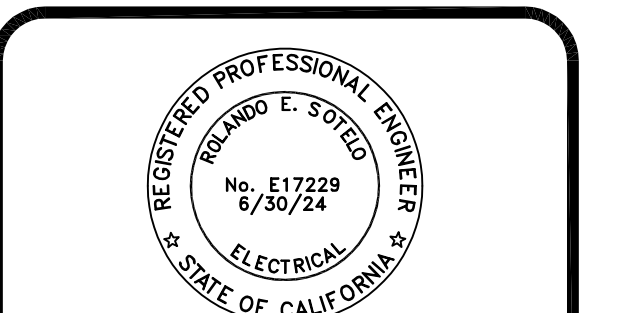

CLIENT	COASTSIDE FIRE PROTECTION DISTRICT
PROJECT NUMBER	230137
DATE	3/28/24
DRAWN BY:	LS
CHECKED BY:	RES

#	REVISIONS DESCRIPTION	DATE

DESIGN DEVELOPMENT
<b>PHOTOMETRIC SITE PLAN</b>

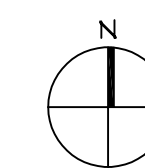
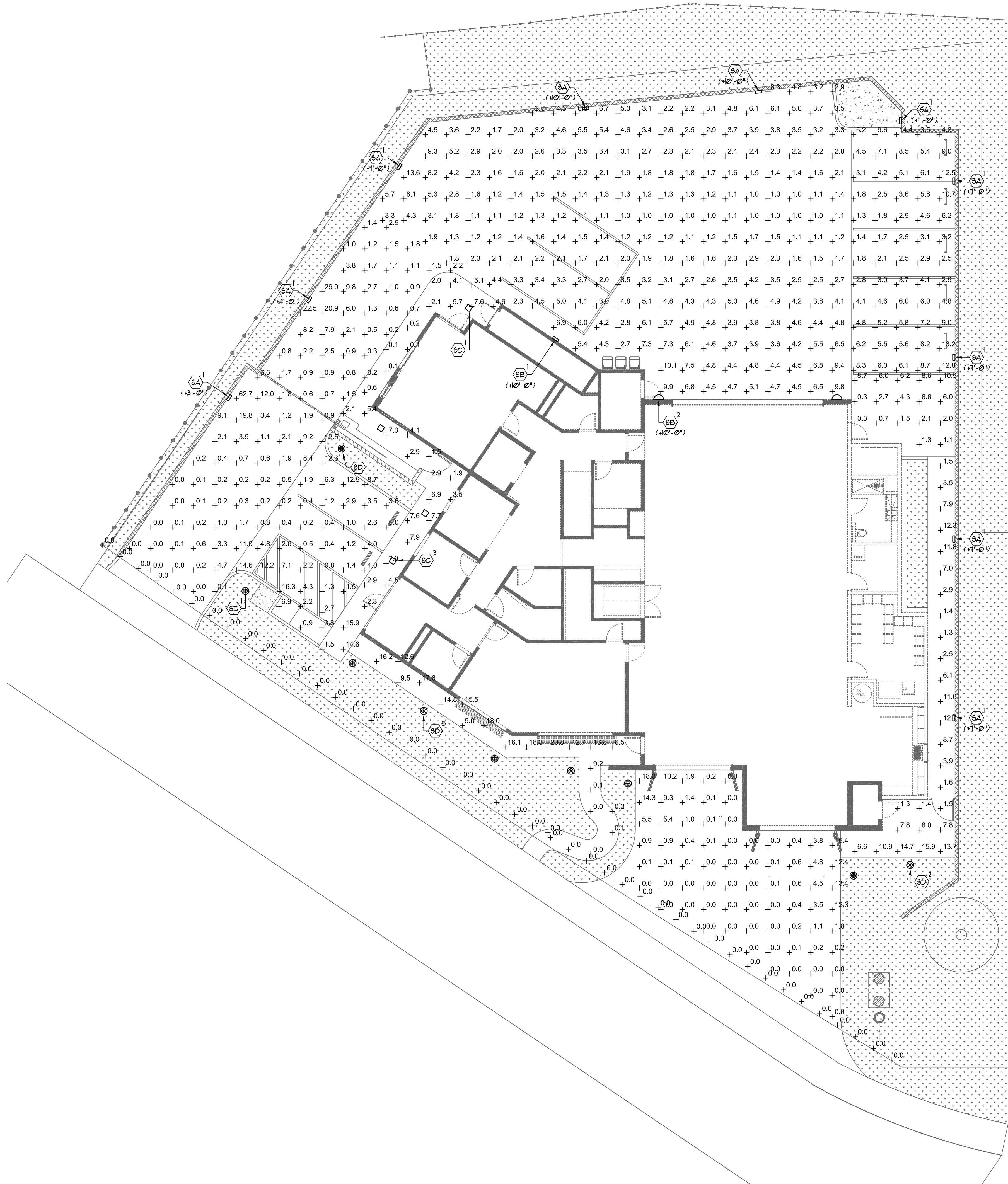



# WPX LED Wall Packs



Catalog Number	
Notes	
Type	<b>Type SA</b>

Hit the Tab key or mouse over the page to see all interactive elements.

## Specifications

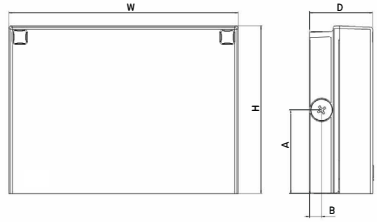

Front View

Side View

Luminaire	Height (H)	Width (W)	Depth (D)	Side Conduit Location		Weight
				A	B	
WPX1	8.1" (20.6 cm)	11.1" (28.3 cm)	3.2" (8.1 cm)	4.0" (10.3 cm)	0.6" (1.6 cm)	6.1 lbs (2.8kg)
WPX2	9.1" (23.1 cm)	12.3" (31.1 cm)	4.1" (10.5 cm)	4.5" (11.5 cm)	0.7" (1.7 cm)	8.2 lbs (3.7kg)
WPX3	9.5" (24.1 cm)	13.0" (33.0 cm)	5.5" (13.7 cm)	4.7" (12.0 cm)	0.7" (1.7 cm)	11.0 lbs (5.0kg)

## Introduction

The WPX LED wall packs are energy-efficient, cost-effective, and aesthetically appealing solutions for both HID wall pack replacement and new construction opportunities. Available in three sizes, the WPX family delivers 1,550 to 9,200 lumens with a wide, uniform distribution.

The WPX full cut-off solutions fully cover the footprint of the HID glass wall packs that they replace, providing a neat installation and an upgraded appearance. Reliable IP66 construction and excellent LED lumen maintenance ensure a long service life. Photocell and emergency egress battery options make WPX ideal for every wall mounted lighting application.

## Ordering Information

EXAMPLE: WPX2 LED 40K MVOLT DDBXD

Series	Color Temperature	Voltage	Options	Finish	
WPX1 LED P1	1,550 Lumens, 11W <sup>1</sup>	<b>30K</b> 3000K	<b>MVOLT</b> 120V - 277V	<b>(blank)</b> <b>None</b>	DDBXD Dark bronze
<b>WPX1 LED P2</b>	<b>2,900 Lumens, 24W</b>	40K 4000K	347 347V <sup>3</sup>	E4WH Emergency battery backup, CEC compliant (4W, 0°C min) <sup>2</sup>	DWHXD White
WPX2 LED	6,000 Lumens, 47W	50K 5000K		E14WC Emergency battery backup, CEC compliant (14W, -20°C min) <sup>2</sup>	<b>DBLXD</b> <b>Black</b>
WPX3 LED	9,200 Lumens, 69W			PE Photocell <sup>3</sup>	Note : For other options, consult factory.

Note: The lumen output and input power shown in the ordering tree are average representations of all configuration options. Specific values are available on request.

### NOTES

- All WPX wall packs come with 6kV surge protection standard, except WPX1 LED P1 package which comes with 2.5kV surge protection standard. Add SPD6KV option to get WPX1 LED P1 with 6kV surge protection. Sample nomenclature: WPX1 LED P1 40K MVOLT SPD6KV DDBXD
- Battery pack options only available on WPX1 and WPX2.
- Battery pack options not available with 347V or PE options.

## FEATURES & SPECIFICATIONS

### INTENDED USE

The WPX LED wall packs are designed to provide a cost-effective, energy-efficient solution for the one-for-one replacement of existing HID wall packs. The WPX1, WPX2 and WPX3 are ideal for replacing up to 150W, 250W, and 400W HID luminaires respectively. WPX luminaires deliver a uniform, wide distribution. WPX is rated for -40°C to 40°C.

### CONSTRUCTION

WPX feature a die-cast aluminum main body with optimal thermal management that both enhances LED efficacy and extends component life. The luminaires are IP66 rated, and sealed against moisture or environmental contaminants.

### ELECTRICAL

Light engine(s) configurations consist of high-efficacy LEDs and LED lumen maintenance of L90/100,000 hours. Color temperature (CCT) options of 3000K, 4000K and 5000K with minimum CRI of 70. Electronic drivers ensure system power factor >90% and THD <20%. All luminaires have 6kV surge protection (Note: WPX1 LED P1 package comes with a standard surge protection rating of 2.5kV. It can be ordered with an optional 6kV surge protection). All photocell (PE) operate on MVOLT (120V - 277V) input.

Note: The standard WPX LED wall pack luminaires come with field-adjustable drive current feature. This feature allows tuning the output current of the LED drivers to adjust the lumen output (to dim the luminaire).

### INSTALLATION

WPX can be mounted directly over a standard electrical junction box. Three 1/2 inch conduit ports on three sides allow for surface conduit wiring. A port on the back surface allows poke-through conduit wiring on surfaces that don't have an electrical junction box. Wiring can be made in the integral wiring compartment in all cases. WPX is only recommended for installations with LEDs facing downwards.

### LISTINGS

CSA Certified to meet U.S. and Canadian standards. Suitable for wet locations. IP66 Rated. DesignLights Consortium® (DLC) qualified product. Not all versions of this product may be DLC qualified. Please check the DLC Qualified Products List at [www.designlights.org/QPL](http://www.designlights.org/QPL) to confirm which versions are qualified. International Dark Sky Association (IDA) Fixture Seal of Approval (FSA) is available for all products on this page utilizing 3000K color temperature only.

### WARRANTY

5-year limited warranty. This is the only warranty provided and no other statements in this specification sheet create any warranty of any kind. All other express and implied warranties are disclaimed. Complete warranty terms located at: [www.acuitybrands.com/CustomerResources/Terms\\_and\\_conditions.aspx](http://www.acuitybrands.com/CustomerResources/Terms_and_conditions.aspx).

Note: Actual performance may differ as a result of end-user environment and application. All values are design or typical values, measured under laboratory conditions at 25°C. Specifications subject to change without notice.



## Performance Data

### Electrical Load

Luminaire	Input Power (W)	120V	208V	240V	277V	347V
WPX1 LED P1	11W	0.09	0.05	0.05	0.04	0.03
WPX1 LED P2	24W	0.20	0.12	0.10	0.09	0.07
WPX2	47W	0.39	0.23	0.20	0.17	0.14
WPX3	69W	0.58	0.33	0.29	0.25	0.20

### Projected LED Lumen Maintenance

Data references the extrapolated performance projections in a 25°C ambient, based on 6,000 hours of LED testing (tested per IESNA LM-80-08 and projected per IESNA TM-21-11).

To calculate LLF, use the lumen maintenance factor that corresponds to the desired number of operating hours below. For other lumen maintenance values, contact factory.

Operating Hours	50,000	75,000	100,000
Lumen Maintenance Factor	>0.94	>0.92	>0.90

### Lumen Output

Luminaire	Color Temperature	Lumen Output
WPX1 LED P1	3000K	1,537
	4000K	1,568
	5000K	1,602
WPX1 LED P2	3000K	2,748
	4000K	2,912
	5000K	2,954
WPX2	3000K	5,719
	4000K	5,896
	5000K	6,201
WPX3	3000K	8,984
	4000K	9,269
	5000K	9,393

### Lumen Ambient Temperature (LAT) Multipliers

Use these factors to determine relative lumen output for average ambient temperatures from 0-50°C (32-122°F).

Ambient	Ambient	Lumen Multiplier
0°C	32°F	1.05
5°C	41°F	1.04
10°C	50°F	1.03
15°C	59°F	1.02
20°C	68°F	1.01
25°C	77°F	1.00
30°C	86°F	0.99
35°C	95°F	0.98
40°C	104°F	0.97

### HID Replacement Guide

Luminaire	Equivalent HID Lamp	WPX Input Power
WPX1 LED P1	100W	11W
WPX1 LED P2	150W	24W
WPX2	250W	47W
WPX3	400W	69W

### Emergency Egress Battery Packs

The emergency battery backup is integral to the luminaire — no external housing or back box is required. The emergency battery will power the luminaire for a minimum duration of 90 minutes and deliver minimum initial output of 550 lumens. Both battery pack options are CEC compliant.

Battery Type	Minimum Temperature Rating	Power (Watts)	Controls Option	Ordering Example
Standard	0°C	4W	E4WH	WPX2 LED 40K MVOLT <b>E4WH</b> DDBXD
Cold Weather	-20°C	14W	E14WC	WPX2 LED 40K MVOLT <b>E14WC</b> DDBXD

## Photometric Diagrams

To see complete photometric reports or download .ies files for this product, visit the Lithonia Lighting [WPX LED](#) homepage. Tested in accordance with IESNA LM-79 and LM-80 standards

#### LEGEND

<span style="display:inline-block; width:10px; height:10px; background-color:#004a99; border:1px solid black;"></span> 0.1 fc
<span style="display:inline-block; width:10px; height:10px; background-color:#0070c0; border:1px solid black;"></span> 0.2 fc
<span style="display:inline-block; width:10px; height:10px; background-color:#0096d6; border:1px solid black;"></span> 0.5 fc
<span style="display:inline-block; width:10px; height:10px; background-color:#99ccff; border:1px solid black;"></span> 1.0 fc

WPX1 LED P1

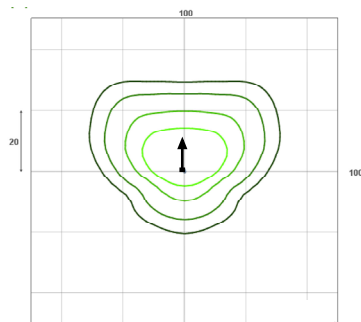

WPX1 LED P2

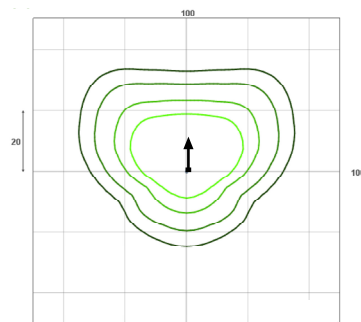

WPX2 LED

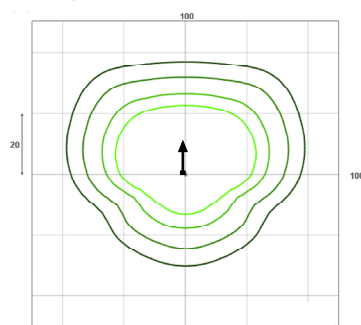

WPX3 LED

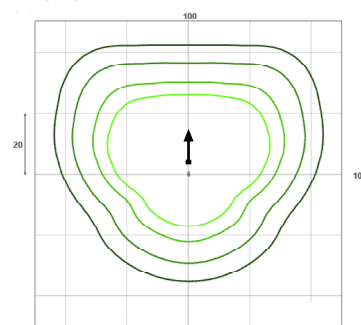

Mounting Height = 12 Feet.



# GEOPAK Series 2

SIZE 2 - TRP2/QSP2/RD12

## Type SB

### FEATURES

- Mid sized architectural wallpacks in three stylish shapes
- Capable of replacing up to 400w HID luminaires
- Type 2, 3, 4F and 4W distributions for a wide variety of applications
- Integral battery backup options
- Control capabilities offer additional energy savings options
- Zero uplight distributions

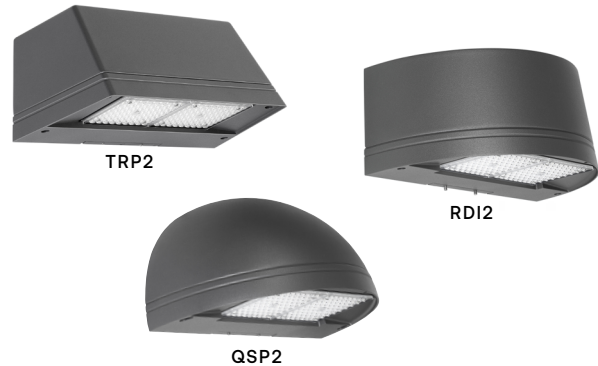

### SPECIFICATIONS

#### CONSTRUCTION

- Die-cast aluminum housing and door
- Seven powder coat standard finishes, plus custom color options
- Meets ASTM B117 with 1,000 hours of salt spray exposure

#### OPTICS

- LEDs deliver up to 15,000 lumens
- Up to 155 lumens per watt (LPW)
- Different lenses offer a variety of distribution patterns - Type 2, 3, 4F & 4W
- CCT: 3000K, 4000K, and 5000K
- CRI: 70 and 80

#### INSTALLATION

- Quick-mount adapter with gasket seal provides easy installation to wall or to recessed junction box (4" square junction box). Fixture attaches by two Allen-head hidden fasteners for tamper resistance
- Back box accessory available for surface conduit application

#### ELECTRICAL

- Optional Dual Drivers & Dual Power Feed
- 120-277, 347 and 480 voltage, 50/60Hz
- Power factor > 90%
- THD (Total Harmonic Distortion) <20%

#### ELECTRICAL (CONTINUED)

- Ambient operating temperature -40°C to 40°C
- Optional: 20kA surge protection device (series); Automatically takes fixture off-line when device is consumed
- Integral Battery Backup provides emergency lighting with 13W of power for the required 90 minutes for path of egress
- Independent dedicated driver and LED array for battery/emergency mode operation

#### CONTROLS

- Drivers are 0-10V dimming standard
- Universal button photocontrol for dusk to dawn energy savings
- Photocell and occupancy sensor options available for complete on/off and dimming control
- Dual Driver option provides 2 drivers within luminaire but only one set of leads exiting the luminaire, where Dual Power Feed provides two drivers which can be wired independently as two sets of leads are extended from the luminaire. Both options can not be included in one same fixture.

#### CERTIFICATIONS

- IP65 rated housing
- Zero uplight (U0), dark sky, neighbor friendly
- Drivers IP66 and RoHS compliant
- This product meets federal procurement law requirements under the Buy American Act (FAR 52.225-9) and Trade Agreements Act (FAR 52.225-11). See Buy American Solutions.

#### WARRANTY

- 5 year limited warranty

KEY DATA	
Lumen Range	3,500-15,000
Wattage Range	24-126
Efficacy Range (LPW)	95-154
Weights lbs. (kg)	16-18 (7.3-8.2)



DATE: \_\_\_\_\_ LOCATION: \_\_\_\_\_

TYPE: \_\_\_\_\_ PROJECT: \_\_\_\_\_

CATALOG #: \_\_\_\_\_

# GEOPAK Series 2

SIZE 2 - TRP2/QSP2/RD12

## ORDERING GUIDE

Example: TRP2-36L-25-3K7-2-UNV-DBT

CATALOG #

### ORDERING INFORMATION

Series	# LEDs - Wattage	CCT/CRI	Distribution	Voltage
<b>TRP2</b> Trapezoid	<b>36L-25</b> 4,200 Lumens (Strike)	<b>27K8</b> 2700K, 70 CRI	<b>2</b> TYPE 2	<b>UNV</b> 120-277V
<b>RD12</b> Radius	<b>36L-39</b> 5,700 Lumens (Strike)	<b>3K7</b> 3000K, 70 CRI	<b>3</b> TYPE 3	<b>120</b> 120V
<b>QSP2</b> Quartersphere	<b>36L-55</b> 7,700 Lumens (Strike)	<b>3K8</b> 3000K, 80 CRI	<b>4W</b> TYPE 4W	<b>208</b> 208V
	<b>36L-85</b> 10,300 Lumens (Strike)	<b>4K7</b> 4000K, 70 CRI	<b>4F</b> TYPE 4 Forward	<b>240</b> 240V
	<b>36L-105</b> 12,300 Lumens (Strike)	<b>4K8</b> 4000K, 80 CRI		<b>277</b> 277V
	<b>36L-120</b> 13,100 Lumens (Strike)	<b>5K7</b> 5000K, 70 CRI		<b>347</b> 347V
	<b>160L-25</b> 3,600 Lumens (Micro Strike)	<b>5K8</b> 5000K, 80 CRI		<b>480</b> 480V
	<b>160L-35</b> 5,500 Lumens (Micro Strike)			
	<b>160L-50</b> 7,700 Lumens (Micro Strike)			
	<b>160L-75</b> 9,700 Lumens (Micro Strike)			
	<b>160L-100</b> 12,000 Lumens (Micro Strike)			
	<b>160L-115</b> 14,600 Lumens (Micro Strike)			

Color	Control Options	Options
<b>BLT</b> Black Matte Textured	<b>PC</b> Button Photocontrol	<b>SF</b> <sup>1</sup> Single fuse & fuse holder
<b>BLS</b> Black Gloss Smooth	<b>NXW</b> NX Wireless Radio (No Sensor)	<b>DF</b> <sup>1</sup> Double fuse & fuse holder
<b>DBT</b> Dark Bronze Matte Textured	<b>NXWS</b> NX Wireless Sensor w/BT	<b>E</b> <sup>2,3,4</sup> Battery pack (0°C)
<b>DBS</b> Dark Bronze Gloss Smooth	<b>BTSO</b> Bluetooth Sensor OMNI	<b>EH</b> <sup>2,3,4</sup> Battery pack (-20°C) with heater
<b>GTT</b> Graphite Matte Textured	<b>CD</b> Customer Dimming	<b>2DR</b> <sup>5</sup> Dual Drivers
<b>LGS</b> Light Grey Gloss Smooth	<b>Mount Height</b>	<b>2PF</b> <sup>2,5</sup> Dual power feeds
<b>PSS</b> Platinum Silver Smooth	<b>-12F</b> Up to 12ft mount height	<b>SP</b> Surge Protector
<b>WHT</b> White Matte Textured		
<b>WHS</b> White Gloss Smooth		
<b>VGT</b> Verde Green Textured		
<b>Color Option</b>		
<b>CC</b> Custom Color		

Notes:

- 1 Must specify voltage
- 2 Battery option not compatible with 2 power feeds
- 3 E and EH options available for 160L-25, 160L-35, 160L-50, 36L-25, 36L-39, and 36L-55
- 4 E and EH available for UNV, 120, 208, 240, 277V
- 5 Option only available with 36L-85, 36L-105, 36L-120, 160L-75, 160L-100, and 160L-115.

### ACCESSORIES (ORDERED SEPARATELY)

Catalog Number	Description
<input type="checkbox"/> WP-BB-DBT	Backbox with four 1/2" threaded conduit holes painted Dark Bronze Texture



DATE: \_\_\_\_\_ LOCATION: \_\_\_\_\_

TYPE: \_\_\_\_\_ PROJECT: \_\_\_\_\_

CATALOG #: \_\_\_\_\_

# GEOPAK Series 2

SIZE 2 - TRP2/QSP2/RD12

## PERFORMANCE DATA (MICRO STRIKE)

Description	Nominal Wattage	System Watts	Dist. Type	5K (5000K NOMINAL 70 CRI)					4K (4000K NOMINAL 70 CRI)					3K (3000K NOMINAL 80 CRI)				
				Lumens	LPW	B	U	G	Lumens	LPW	B	U	G	Lumens	LPW	B	U	G
160L	25	24.4	2	3734	153	1	0	1	3663	150	1	0	1	3557	146	1	0	1
			3	3744	154	1	0	1	3672	151	1	0	1	3565	146	1	0	1
			4F	3721	153	1	0	1	3651	150	1	0	1	3544	145	1	0	1
			4W	3704	152	1	0	1	3633	149	1	0	1	3528	145	1	0	1
	35	37.7	2	5602	149	1	0	2	5495	146	1	0	2	5335	142	1	0	2
			3	5616	149	1	0	2	5509	146	1	0	2	5348	142	1	0	2
			4F	5582	148	1	0	2	5476	145	1	0	2	5316	141	1	0	2
			4W	5556	147	2	0	2	5450	145	1	0	2	5291	140	1	0	2
	50	56.2	2	7880	140	1	0	2	7730	138	1	0	2	7504	134	1	0	2
			3	7899	141	1	0	2	7749	138	1	0	2	7523	134	1	0	2
			4F	7852	140	1	0	2	7703	137	1	0	2	7478	133	1	0	2
			4W	7815	139	1	0	2	7666	136	1	0	2	7443	132	1	0	2
	75	71.9	2	9971	139	2	0	2	9781	136	2	0	2	9496	132	1	0	2
			3	9996	139	2	0	2	9805	136	2	0	2	9520	132	1	0	2
			4F	9936	138	1	0	2	9747	136	2	0	2	9463	132	1	0	2
			4W	9890	138	1	0	2	9701	135	2	0	2	9419	131	1	0	2
	100	95.7	2	12361	129	2	0	2	12126	127	2	0	2	11772	123	2	0	2
			3	12392	129	2	0	2	12156	127	2	0	2	11802	123	2	0	2
			4F	12318	129	2	0	2	12083	126	2	0	2	11731	123	2	0	2
			4W	12260	128	2	0	2	12027	126	2	0	2	11676	122	2	0	2
	115	116.6	2	14990	129	2	0	2	14705	126	2	0	2	14277	122	2	0	2
			3	15088	129	3	0	2	14801	127	3	0	3	14370	123	3	0	3
			4F	14970	128	2	0	3	14685	126	2	0	3	14257	122	2	0	2
			4W	14981	128	2	0	3	14695	126	3	0	3	14267	122	2	0	3

## MULTIPLIER (MICRO STRIKE)

Micro Strike Lumen Multiplier			
CCT	70CRI	80CRI	90CRI
2700K	-	0.869	-
3000K	0.945	0.832	0.626
3500K	-	0.900	-
4000K	1.027	0.951	0.718
5000K	1.000	0.937	0.791
Monochromatic Amber Multiplier			
Amber	0.719		



DATE: \_\_\_\_\_ LOCATION: \_\_\_\_\_

TYPE: \_\_\_\_\_ PROJECT: \_\_\_\_\_

CATALOG #: \_\_\_\_\_

# GEOPAK Series 2

SIZE 2 - TRP2/QSP2/RD12

## PERFORMANCE DATA (STRIKE)

Description	Nominal Wattage	System Watts	Dist. Type	5K (5000K NOMINAL 70 CRI)					4K (4000K NOMINAL 70 CRI)					3K (3000K NOMINAL 80 CRI)				
				Lumens	LPW	B	U	G	Lumens	LPW	B	U	G	Lumens	LPW	B	U	G
36L	25	32.1	2	4131	130	1	0	1	4208	132	1	0	1	3861	121	1	0	1
			3	4150	130	1	0	2	4227	132	1	0	2	3878	121	1	0	1
			4F	4163	130	1	0	1	4241	132	1	0	1	3891	122	1	0	1
			4W	4156	130	1	0	2	4233	132	1	0	2	3884	121	1	0	2
	39	45.1	2	5618	125	1	0	1	5723	127	1	0	1	5251	116	1	0	1
			3	5644	125	1	0	2	5749	127	1	0	2	5274	117	1	0	2
			4F	5662	126	1	0	2	5768	128	1	0	2	5291	117	1	0	2
			4W	5652	125	1	0	2	5757	128	1	0	2	5282	117	1	0	2
	55	63.1	2	7458	118	1	0	2	7659	121	1	0	2	6970	110	1	0	2
			3	7552	120	1	0	2	7694	122	1	0	2	7058	112	1	0	2
			4F	7577	120	1	0	2	7718	122	1	0	2	7081	112	1	0	2
			4W	7564	120	1	0	3	7705	122	1	0	3	7069	112	1	0	3
	85	88.0	2	10121	115	2	0	2	10311	117	2	0	2	9459	107	2	0	2
			3	10167	116	1	0	3	10357	118	1	0	3	9502	108	1	0	3
			4F	10200	116	1	0	2	10390	118	1	0	2	9532	108	1	0	2
			4W	10182	116	1	0	3	10372	118	1	0	3	9516	108	1	0	3
	105	111.7	2	12022	108	2	0	2	12247	110	2	0	2	11235	101	2	0	2
			3	12075	108	2	0	3	12301	110	2	0	3	11285	101	2	0	3
			4F	12115	108	1	0	3	12341	110	1	0	3	11322	101	1	0	2
			4W	12093	108	2	0	3	12319	110	2	0	3	11302	101	1	0	3
	120	126.2	2	12889	102	2	0	2	13130	104	2	0	2	12046	95	2	0	2
			3	12947	103	2	0	3	13189	105	2	0	3	12100	96	2	0	3
			4F	12989	103	1	0	3	13232	105	1	0	3	12139	96	1	0	3
			4W	12966	103	2	0	3	13208	105	2	0	3	12118	96	1	0	3

## MULTIPLIER (STRIKE)

Strike Lumen Multiplier			
CCT	70CRI	80CRI	90CRI
2700K	0.900	0.810	0.62
3000K	0.933	0.853	0.659
3500K	0.959	0.894	0.711
4000K	1.000	0.900	0.732
5000K	1.000	0.900	0.732
Monochromatic Amber Multiplier			
Amber	0.255		



DATE: \_\_\_\_\_ LOCATION: \_\_\_\_\_

TYPE: \_\_\_\_\_ PROJECT: \_\_\_\_\_

CATALOG #: \_\_\_\_\_

# GEOPAK Series 2

SIZE 2 - TRP2/QSP2/RD12

## PROJECTED LUMEN MAINTENANCE

Ambient Temperature	OPERATING HOURS					
	0	25,000	TM-21-t1 36,000	50,000	100,000	L70 (Hours)
25°C / 77°F	1.00	0.97	0.96	0.95	0.91	408,000
40°C / 104°F	0.99	0.96	0.95	0.94	0.89	356,000

For Microstrike LEDs

## LUMINAIRE AMBIENT TEMPERATURE FACTOR (LATF)

Ambient Temperature	Lumen Multiplier	
0°C	32°F	1.03
10°C	50°F	1.01
20°C	68°F	1.00
25°C	77°F	1.00
30°C	86°F	0.99
40°C	104°F	0.98
50°C	122°F	0.97

Use these factors to determine relative lumen output for average ambient temperatures from 0-40°C (32-104°F).

## ELECTRICAL DATA

# OF LEDS	Nominal Wattage	Input Voltage	Oper. Current (Amps)	System Power (Watts)
160L	25	120	0.20	24.4
		208	0.12	
		240	0.10	
		277	0.09	
		347	0.07	
		480	0.05	
	35	120	0.31	37.7
		208	0.18	
		240	0.16	
		277	0.14	
		347	0.11	
		480	0.08	
	50	120	0.47	56.2
		208	0.27	
		240	0.23	
		277	0.20	
		347	0.16	
		480	0.12	
	75	120	0.60	72.0
		208	0.35	
		240	0.30	
		277	0.26	
		347	0.21	
		480	0.15	
100	120	0.80	95.7	
	208	0.46		
	240	0.40		
	277	0.35		
	347	0.28		
	480	0.20		
115	120	0.97	116.6	
	208	0.56		
	240	0.49		
	277	0.42		
	347	0.34		
	480	0.24		

# OF LEDS	Nominal Wattage	Input Voltage	Oper. Current (Amps)	System Power (Watts)
36L	25	120	0.27	32.1
		208	0.15	
		240	0.13	
		277	0.12	
		347	0.09	
		480	0.07	
	39	120	0.38	45.1
		208	0.22	
		240	0.19	
		277	0.16	
		347	0.13	
		480	0.09	
	55	120	0.53	63.1
		208	0.30	
		240	0.26	
		277	0.23	
		347	0.18	
		480	0.13	
	85	120	0.73	88.0
		208	0.42	
		240	0.37	
		277	0.32	
		347	0.25	
		480	0.18	
105	120	0.93	111.7	
	208	0.54		
	240	0.47		
	277	0.40		
	347	0.32		
	480	0.23		
120	120	1.05	126.2	
	208	0.61		
	240	0.53		
	277	0.46		
	347	0.36		
	480	0.26		

# GEOPAK Series 2

SIZE 2 - TRP2/QSP2/RDI2

## PHOTOMETRY

The following diagrams represent the general distribution options offered for this product. For detailed information on specific product configurations, see website photometric test reports.

TRP2-50W-4K7-T2

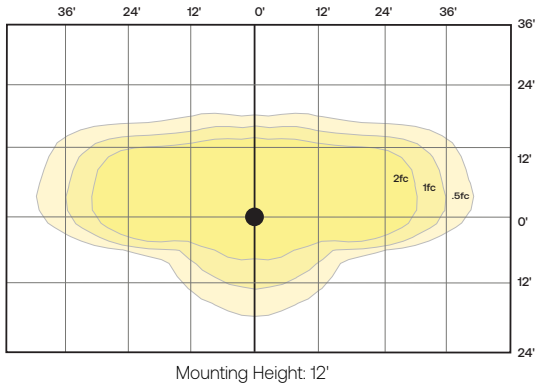

TRP2-50W-4K7-T3

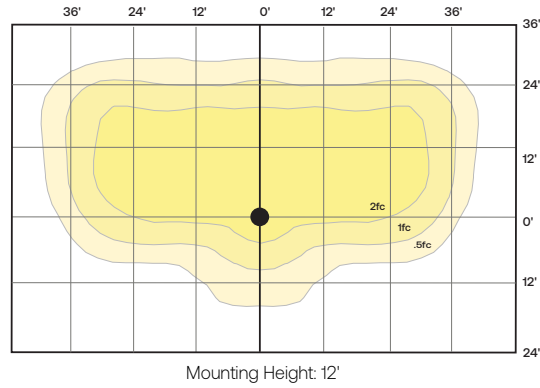

TRP2-50W-4K7-T4F

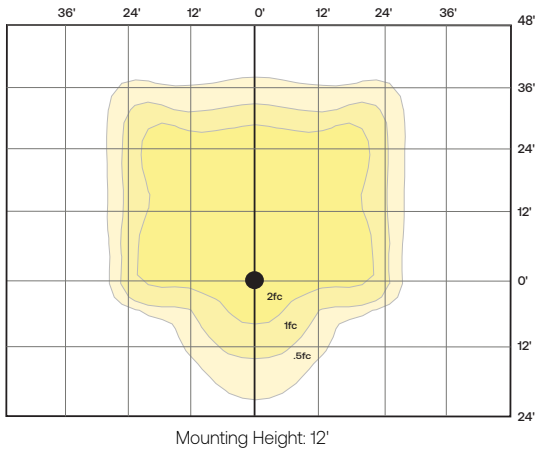

TRP2-50W-4K7-T4W

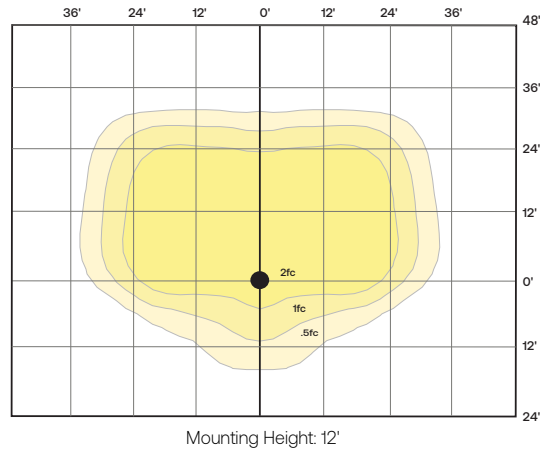

# GEOPAK Series 2

SIZE 2 - TRP2/QSP2/RDI2

## DIMENSIONS

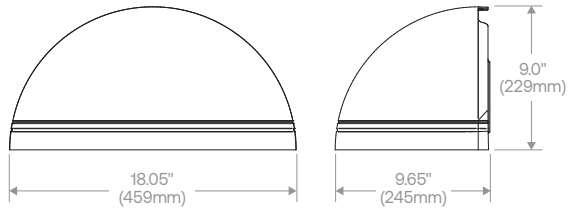

QSP2  
Weight:  
15 lbs (6.8 kg)

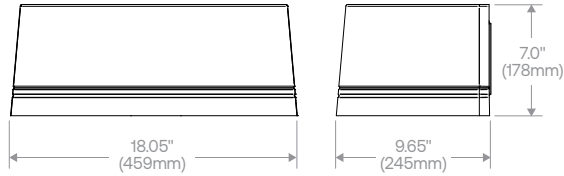

RDI2  
Weight:  
16 lbs (7.3 kg)

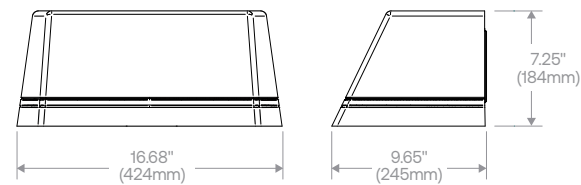

TRP2  
Weight:  
16 lbs (7.3 kg)

## ADDITIONAL INFORMATION

### PHOTOMETRICS - BATTERY BACK UP

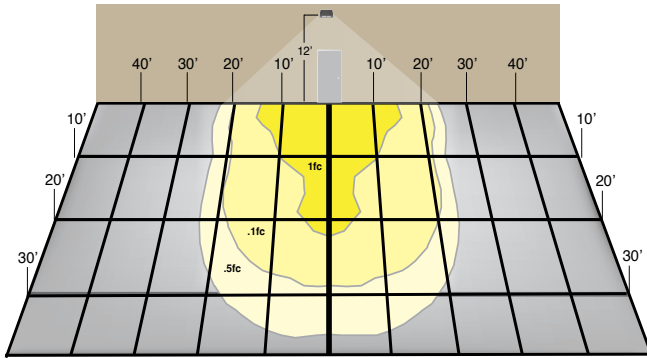

36L - 12' Mounting Height

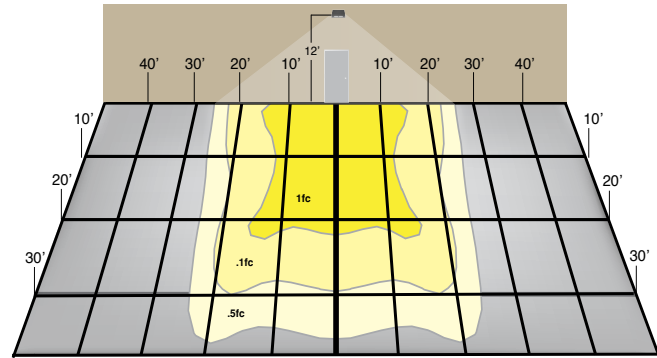

160L - 12' Mounting Height

Provides Life Safety Code average illuminance of 1.0 fc. Assumes open space with no obstructions and mounting height of 12'.

Diagrams for illustration purposes only, please consult factory for application layout.

### CONTROL OPTIONS



Programmable occupancy sensor offers greater control and energy savings with adjustable delay and dimming levels (Factory default is 10%)

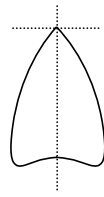

## General Illumination Square Shower Downlight

6"

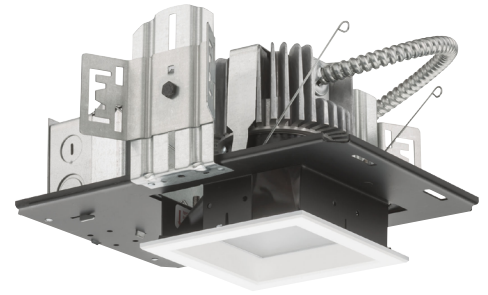

OVERVIEW

### Feature Set

- Wipe down flush or regressed lens
- NSF2 Splash/Non-food Zone
- Fully serviceable and upgradeable lensed LED light engine
- 70% lumen maintenance at 60,000 hours
- 2.5 MacAdam ellipse; 85 CRI typical, 90+ CRI optional
- IP66 rated room-side, Fixtures are wet location, covered ceiling
- Anti-microbial paint finish, optional
- Non-conductive dead-front trim
- Suitable for steam room applications
- UGR of zero for fixtures aimed at nadir with a cut-off equal to or less than 60deg per CIE 117-1995 Discomfort Glare in Interior Lighting. [UGR FAQ](#)

### Distribution



### Superior Performance (Flush, Clear Lens)

Nominal Lumens	1000	1500	2000	2500
Delivered	870	1292	1754	2219
Wattage	9.6	14.7	19.7	24.7
Efficacy	90.6	87.9	89.0	89.8

\*Lumen output for 80CRI - 3500K

COMPLEMENTARY PRODUCTS

### Coordinated Apertures | Multiple Layers of Light



General Illumination Layer | EVO



High Center Beam Layer | Incito



EVO + Incito — Multiple Layers of Light

### Core



### Healthcare



### Special Applications





A+ Capable options indicated by this color background.

Luminaire Type:

Catalog Number:

EXAMPLE: EV06SQSH 35/20 DFRAMF SOL MVOLT EZ1

Series	Color Temperature	Nominal Lumen Values	Lens Setting	Lens	Voltage
<b>EV06SQSH</b>	27/ 2700 K <b>30/ 3000 K</b> 35/ 3500 K 40/ 4000 K 50/ 5000 K	10 1000 lumens <b>15 1500 lumens</b> 20 2000 lumens 25 2500 lumens	<b>DFR</b> Regressed lensed white painted trim <b>DFR</b> <b>Flush lensed white painted trim</b> <b>DFRBR</b> Regressed lensed black painted trim <b>DFRBR</b> Flush lensed black painted trim <b>DFRAMF</b> Regressed lensed trim with anti-microbial finish <b>DFRAMF</b> Flush lensed trim with anti-microbial finish	<b>SOL</b> Textured Lens <b>SMO</b> <b>Smooth Clear Lens</b>	<b>MVOLT</b> <b>120</b> 277

Driver <sup>1</sup>	Control Interface	Emergency	Options
<b>EZ1</b> eldoLED 0-10V ECOdrive. Linear dimming to 1% min. <b>EZB</b> eldoLED 0-10V SOLOdrive. Logarithmic dimming to <1%. <b>EDAB</b> eldoLED SOLOdrive DALI. Logarithmic dimming to <1%.	<b>NLT<sup>2</sup></b> nLight™ dimming pack controls <b>NLTER<sup>2,3</sup></b> nLight™ dimming pack controls emergency circuit	<b>(blank)</b> no emergency option <b>ELR<sup>4</sup></b> Emergency battery pack, 10W, with remote test switch. <b>E10WCPR<sup>4</sup></b> <b>Emergency battery pack, 10W Constant Power, CA Title 20 compliant with remote test switch</b> <b>BGTD</b> Bodine generator transfer device. Specify 120V or 277V.	<b>SF</b> Single fuse. Specify 120V or 277V. <b>90CRI</b> High CRI (90+). <b>CP</b> Chicago Plenum. Specify 120V or 277V.

**ACCESSORIES — order as separate catalog numbers (shipped separately)**

**ISD BC** 0-10V wallbox dimmer. Refer to [ISD-BC](#).

**ORDERING NOTES**

1. Refer to [TECH-240](#) for compatible dimmers.
2. Specify voltage.
3. For use with generator supply EM power. Will require an emergency hot feed and normal hot feed.
4. Not available with CP option.

**Optical Assembly**

Fully serviceable and upgradeable lensed LED light engine, both the driver and light engine are suitable for field maintenance and are serviceable from above or below the ceiling.

Unitized optics shall have mechanical attachment of the light engine to the lower reflector for complete optical alignment.

**Electrical**

The luminaire shall operate from a 50 or 60 Hz ±3 Hz AC line over a voltage ranging from 120 VAC to 277 VAC. The fluctuations of line voltage shall have no visible effect on the luminous output.

The luminaire shall have a power factor of 90% or greater at all standard operating voltages and full luminaire output.

Sound Rated A+. Driver shall be >80% efficient at full load across all input voltages.

Input wires shall be 18AWG, 300V minimum, solid copper. All drivers are ROHS compliant.

**Controls**

Luminaire shall be equipped with interface for nLight wired network with integral power supply as per specification.

**Dimming**

The luminaire shall be capable of continuous dimming without perceivable stroboscopic flicker as measured by flicker index (ANSI/IES RP-16-10) over a range of 100 – 10%, 100 – 1.0% or 100 – 0.1% of rated lumen output with a smooth shut off function to step to 0%.

eldoLED LED drivers shall conform to IEEE P1789 standards. Alternatively, manufacturers must demonstrate conformance with product literature and testing which demonstrates this performance. Systems that do not meet IEEE P1789 will not be considered.

Driver is inaudible in 24dB environment, and stable when input voltage conditions fluctuate over what is typically experienced in a commercial environment.

**Construction**

Luminaire housing shall be constructed of 16-gauge galvanized steel and have preinstalled telescopic mounting bars with maximum 32" and minimum 15" extension and 4" vertical adjustment.

Luminaires shall be suitable for installation in ceilings up to 1½" thick.

Tool-less adjustments shall be possible after installation.

The assembly and manufacturing process for the luminaire shall be designed to assure all internal components are adequately supported to withstand mechanical shock and vibration.

25°C ambient temperature standard (1/2" clearance on all sides from non-combustible materials in non-IC applications, unless marked spacing noted otherwise). For use in insulated ceilings, a 3" clearance on all sides from insulation is required (unless marked spacing noted otherwise).

**Listings**

Fixtures are CSA certified to meet US and Canadian standards: All fixtures manufactured in strict accordance with the appropriate and current requirements of the "Standards for Safety" to UL, wet location covered ceiling.

**Photometrics**

LEDs tested to LM-80 standards. Measured by IESNA Standard LM-79-08 in an accredited lab. Lumen output shall not decrease by more than 30% over the minimum operational life of 60,000 hours.

Color appearance from luminaire to luminaire of the same type and in all configurations, shall be consistent both initially and at 60,000 hours and operate within a tolerance of <2.5 MacAdam ellipse as defined by a point at the intersection of the CCT line and the black body locus line in CIE chromaticity space.

**Buy American Act**

This product is assembled in the USA and meets the Buy America(n) government procurement requirements under FAR, DFARS and DOT regulations. Please refer to [www.acuitybrands.com/buy-american](http://www.acuitybrands.com/buy-american) for additional information.

**Warranty**

5-year limited warranty. This is the only warranty provided and no other statements in this specification sheet create any warranty of any kind. All other express and implied warranties are disclaimed. Complete warranty terms located at: [www.acuitybrands.com/support/warranty/terms-and-conditions](http://www.acuitybrands.com/support/warranty/terms-and-conditions)

**Note:**

Actual performance may differ as a result of end user environment and application. All values are design or typical values, measured under laboratory conditions at 25 °C.

**A+ Capable Luminaire**

This item is an A+ capable luminaire, which has been designed and tested to provide consistent color appearance and out-of-the-box control compatibility with simple commissioning.

- All configurations of this luminaire meet the Acuity Brands' specification for chromatic consistency
- This luminaire is part of an A+ Certified solution for nLight® control networks when ordered with drivers marked by a shaded background\*
- This luminaire is part of an A+ Certified solution for nLight® control networks, providing advanced control functionality at the luminaire level, when selection includes driver and control options marked by a shaded background\*

To learn more about A+, visit [www.acuitybrands.com/aplus](http://www.acuitybrands.com/aplus).

\*See ordering tree for details

DIMENSIONAL DATA

\*Dimensions in inches [centimeters]

Aperture: 6 1/4" [15.9]	Ceiling Opening: 7 1/8" [18.1] self-flanged
Overlap Trim: 7 1/2" [19.1]	7 1/4" [18.4] flangeless

**Standard**

weight:  
Housing = 7.8 lbs  
Trim = 0.9 lbs

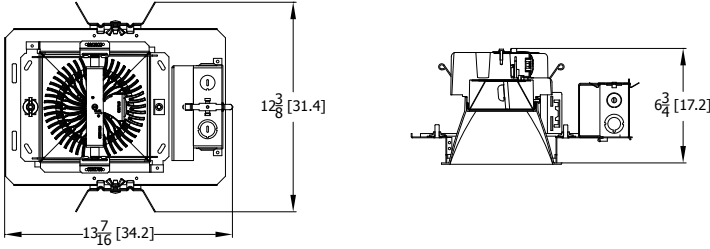

**Battery Pack**

Weight: Battery only = 2.5 lbs

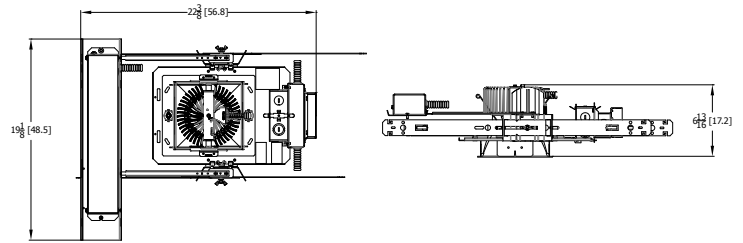

**CP**

Weight: CP housing only = 13 lbs

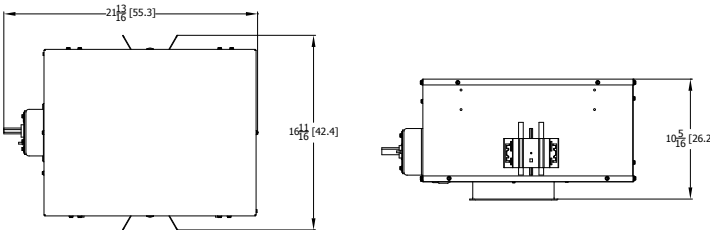

EVO - eldoLED Driver Default Dimming Curve			
Nomenclature	Min Dimming	Driver Dim Curve	Control Dim Curve
EZ1	1%	Linear	Linear/Logarithmic
EXA1	1%	Linear	Linear/Logarithmic
EZB	<1%	Logarithmic	Linear
EDAB	<1%	Logarithmic	Linear
EXAB	<1%	Logarithmic	Linear
EDXB	<1%	Logarithmic	Linear

Driver		Control Provided (note: 347V/UVOLT versions provided with 347 option selected)	
Nomenclature	Description	NLT	NLTER
GZ10	0-10V driver dims to 10%	nPP16 D EFP	nPP16 D ER EFP
GZ1	0-10V driver dims to 1%	nPP16 D EFP	nPP16 D ER EFP
EZ1	eldoLED 0-10V ECOdrive	nPS 80 EZ	nPS 80 EZ ER
EZB	eldoLED 0-10V SOLOdrive	nPS 80 EZ	nPS 80 EZ ER

**How to Estimate Delivered Lumens in Emergency Mode**

**Delivered Lumens = 1.25 x P x LPW**

P = Output power of emergency driver. P = 10W for PS1055CP

LPW = Lumen per watt rating of the luminaire. This information is available on the ABL luminaire spec sheet.

Photometry

**EV06SQSH 35/25 DFF SMO 80CRI INPUT WATTS: 24.7W, DELIVERED LUMENS: 2219.5LM, LPW = 90, 0.87 S/MH, TEST NO: LTL29890P89**

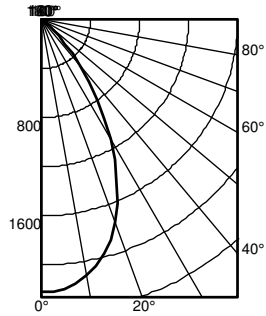

Ave	Lumens	Zone	Lumens	% Lamp
0	2222	0° - 30°	1420.1	64.0
5	2200	0° - 40°	1915.2	86.3
15	1980	0° - 60°	2192.7	98.8
25	1456	0° - 90°	2218.6	100.0
35	795	90° - 120°	0.0	0.0
45	274	90° - 130°	0.0	0.0
55	56	90° - 150°	0.3	0.0
65	16	90° - 180°	0.9	0.0
75	7	0° - 180°	2219.5	*100.0
85	2			
90	0			

\*Efficiency

Mounting Height	Initial FC		50% beam -		10% beam -	
	Center Beam	Diameter	FC	Diameter	FC	FC
8.0	73.5	5.0	36.7	9.3	7.3	
10.0	39.5	6.9	19.7	12.6	3.9	
12.0	24.6	8.7	12.3	16.0	2.5	
14.0	16.8	10.5	8.4	19.4	1.7	
16.0	12.2	12.4	6.1	22.7	1.2	

**EV06SQSH 35/25 DFF SOL 80CRI INPUT WATTS: 24.7W, DELIVERED LUMENS: 2124.7LM, LPW = 86, 0.96 S/MH, TEST NO: LTL29889P89**

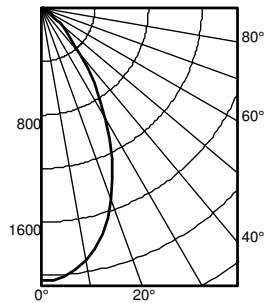

Ave	Lumens	Zone	Lumens	% Lamp
0	2040	0° - 30°	1243.3	58.5
5	2015	0° - 40°	1673.6	78.8
15	1752	0° - 60°	2013.1	94.7
25	1247	0° - 90°	2124.7	100.0
35	688	90° - 180°	0.0	0.0
45	292	0° - 180°	2124.7	*100.0
55	116			
65	62			
75	36			
85	10			
90	2			

\*Efficiency

Mounting Height	Initial FC		50% beam -		10% beam -	
	Center Beam	Diameter	FC	Diameter	FC	FC
8.0	67.4	4.8	33.7	9.3	6.7	
10.0	36.3	6.6	18.1	12.6	3.6	
12.0	22.6	8.3	11.3	16.0	2.3	
14.0	15.4	10.1	7.7	19.4	1.5	
16.0	11.2	11.8	5.6	22.7	1.1	

**EV06SQSH 35/25 DFR SMO 80CRI INPUT WATTS: 24.7W, DELIVERED LUMENS: 1820.8LM, LPW = 73.7, 0.9 S/MH, TEST NO: LTL29892P93**

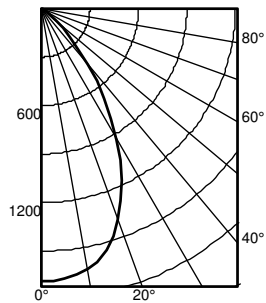

Ave	Lumens	Zone	Lumens	% Lamp
0	1690	0° - 30°	1123.6	61.7
5	1677	0° - 40°	1547.6	85.0
15	1550	0° - 60°	1800.7	98.9
25	1172	0° - 90°	1820.8	100.0
35	683	90° - 180°	0.0	0.0
45	251	0° - 180°	1820.8	*100.0
55	50			
65	12			
75	6			
85	1			
90	0			

\*Efficiency

Mounting Height	Initial FC		50% beam -		10% beam -	
	Center Beam	Diameter	FC	Diameter	FC	FC
8.0	55.9	5.2	27.9	9.6	5.6	
10.0	30.0	7.1	15.0	13.1	3.0	
12.0	18.7	9.1	9.4	16.6	1.9	
14.0	12.8	11.0	6.4	20.1	1.3	
16.0	9.3	12.9	4.6	23.6	0.9	

**EV06SQSH 35/25 DFR SOL 80CRI INPUT WATTS: 24.7W, DELIVERED LUMENS: 1655LM, LPW = 67, 0.85 S/MH, TEST NO: LTL29891P89**

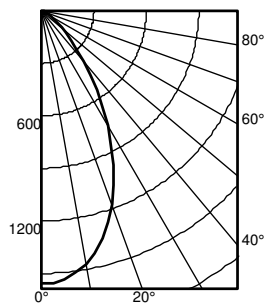

Ave	Lumens	Zone	Lumens	% Lamp
0	1560	0° - 30°	962.8	58.2
5	1539	0° - 40°	1309.3	79.1
15	1349	0° - 60°	1586.5	95.9
25	972	0° - 90°	1655.0	100.0
35	554	90° - 180°	0.0	0.0
45	242	0° - 180°	1655.0	*100.0
55	93			
65	44			
75	20			
85	2			
90	0			

\*Efficiency

Mounting Height	Initial FC		50% beam -		10% beam -	
	Center Beam	Diameter	FC	Diameter	FC	FC
8.0	51.6	4.9	25.8	9.5	5.2	
10.0	27.7	6.6	13.9	12.9	2.8	
12.0	17.3	8.4	8.6	16.3	1.7	
14.0	11.8	10.2	5.9	19.8	1.2	
16.0	8.6	12.0	4.3	23.2	0.9	

DFF SMO - Flush Clear				
Nominal Lumens	1000	1500	2000	2500
Delivered	870	1292	1754	2219
Wattage	9.6	14.7	19.7	24.7
Efficacy	90.6	87.9	89.0	89.8

\*Lumen output for CRI80 - 3500K

DFF SOL - Flush Textured				
Nominal Lumens	1000	1500	2000	2500
Delivered	833	1238	1680	2125
Wattage	9.6	14.7	19.7	24.7
Efficacy	86.8	84.2	85.3	86.0

\*Lumen output for CRI80 - 3500K

DFR SMO - Flush Clear				
Nominal Lumens	1000	1500	2000	2500
Delivered	714	1061	1440	1821
Wattage	9.6	14.7	19.7	24.7
Efficacy	74.4	72.2	73.1	73.7

\*Lumen output for CRI80 - 3500K

DFR SOL - Regressed Textured				
Nominal Lumens	1000	1500	2000	2500
Delivered	649	964	1309	1655
Wattage	9.6	14.7	19.7	24.7
Efficacy	67.6	65.6	66.4	67.0

\*Lumen output for CRI80 - 3500K

CCT/CRI Multiplier Table		
CRI	CCT	Multiplier
80	2700K	0.96
	300K	1.00
	3500K	1.00
	4000K	1.01
90	5000K	1.07
	2700K	0.80
	300K	0.83
	3500K	0.85
	4000K	0.87
	5000K	0.91

nLIGHT

**nLight®** The nLight® solution is a digital networked lighting control system that provides both energy savings and increased user configurability by cost effectively integrating time-based, daylight-based, sensor-based and manual lighting control schemes.

**nLight® Wired Control Accessories**

Order as separate catalog number. Visit [nLight](#).

**Wall Switches**

	Model Number
On/Off single pole	nPODM (color)
On/Off two pole	nPODM 2P (color)
On/Off & raise/lower single pole	nPOD DX (color)
On/Off & raise/lower two pole	nPODM 2P DX (color)
Graphic touchscreen	nPOD GFX (color)

**Photocell Controls**

Dimming	nCM ADCX
---------	----------

**nLight® Wired Control Accessories (cont.)**

Occupancy Sensors (PIR/dual tech)	Model Number
Small motion 360°, ceiling	nCM 9 / nCM PDT 9
Large motion 360°, ceiling	nCM 10 / nCM PDT 10
Wide View	nWV 16 / nWV PDT 16
Wall switch with raise/lower	nWSX LV DX / nWSX PDT LV DX

**Cat-5 Cables (plenum rated)**

10', CAT5	CAT5 10FT J1
15', CAT5	CAT5 15FT J1

**Possibilities for nLight® wired**

Fixtures ordered *without* the NLT option

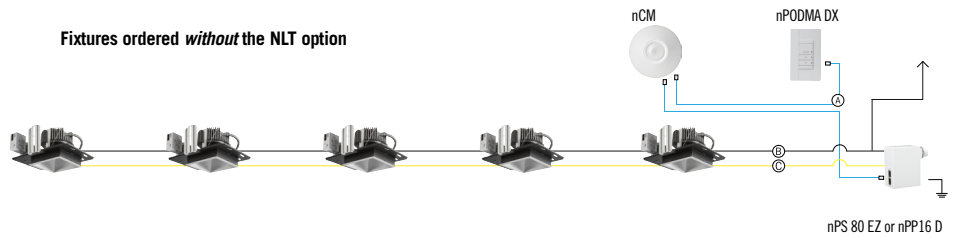

Fixtures ordered *with* the NLT option

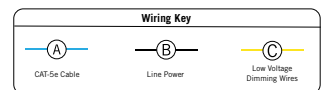
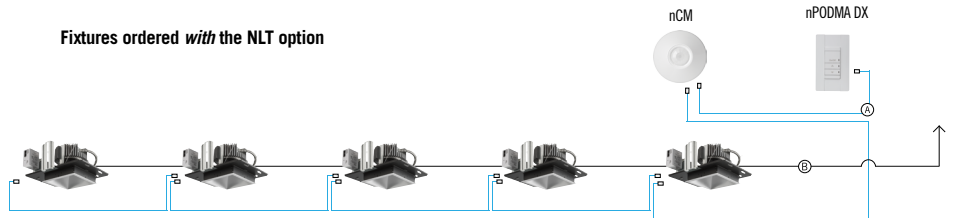

# SOLID STATE LIGHTING

## TORNADO SERIES-LED

### SPECIFICATIONS

#### HOUSING

Durable corrosion resistant low copper cast aluminum alloy A356 (<0.2% Cu) having a minimum wall thickness of 1/4". Top is crowned for water run off, and retainer screw cavities are open for drainage. Top is fully gasketed and secured by (4) stainless steel allen screws. Access Panel(s) is fully gasketed and retained by (2) stainless steel allen screws located below the lens. Body secures to Mounting Stanchion by means of a cast aluminum wedge lock secured by a single stainless steel bolt and accessed through the access panel.

#### LED OPTICAL MODULE

Low copper A356 alloy (<.2% copper) cast aluminum housing. Integrated clear tempered 3/16" glass lens sealed with a continuous silicone gasket protects emitters (LED's) and emitter Reflector-Prism optics, and seals the module from water intrusion and environmental contaminants. LED's are available in standard Neutral White (4000K), or optional Cool White (5000K) or Warm White (3000K). Each emitter is optically controlled by a Reflector-Prism injection molded from H12 acrylic (3 types per module; one from 0° - 50°; one from 50° - 65°; one from 65° - 72°). Each Reflector-Prism has indexing pins for aiming and is secured to an optical plate made of matte black anodized aluminum. The optical plate locates every Reflector-Prism over an emitter. Reflector-Prisms are secured to the optical plate with a UV curing adhesive. The Reflector-Prisms are arrayed to produce IES Type II, IES Type III, IES Type IV, and IES Type V-SQ distributions. The entire Optical Module is field rotatable in 90° increments. Both module and drivers are factory wired using water resistant, insulated cord. Lens, module and drivers are field replaceable.

#### LED EMITTERS

High Output LED's are driven at 350mA for nominal 1 Watt output each. LED's are available in standard Neutral White (4000K), or optional Cool White (5000K) or Warm White (3000K). Consult Factory for other LED options.

#### LED DRIVER

UL and CUL recognized High Power Factor, Constant Current LED drivers operate on input voltages from 120-277VAC, 50/60hz. Consult Factory for 347-480VAC. Driver is mechanically fastened to a retaining bracket. Main power quick disconnect provided. Driver has a minimum 4KV of internal surge protection, 10KV & 20KV Surge Protector optional. Dimming and High-Low Driver options available.

#### FINISH

Electrostatically applied TGIC Polyester Powder Coat on substrate prepared with 20 PSI power wash at 140°F. Four step iron phosphate pretreatment for protection and paint adhesion. 400°F bake for maximum hardness and durability. Texture finish is standard.

PROJECT NAME: \_\_\_\_\_

FIXTURE TYPE: \_\_\_\_\_

Type SD

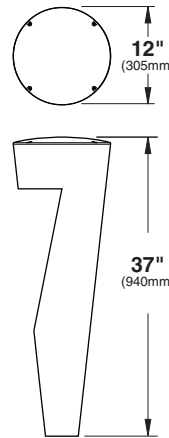

TNA\*

\* SHOWN WITH RIBBED ACCESS PANEL -RAP PATENT PENDING

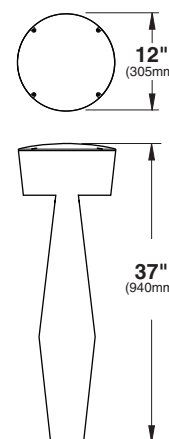

TNS

PATENT PENDING

MADE IN THE  
USA

2023080

U.S. ARCHITECTURAL  
LIGHTING

# TORNADO SERIES - LED

## S P E C I F I C A T I O N S

### PANEL OPTIONS



#### RAP Raised Access Panel

Raised ribs in radiating pattern on Access Panel.

For TNS, both Access Panels will be raised.

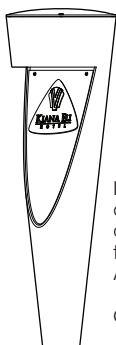

#### Signature Medallion

Logos, medallions and other symbols can be attached to the standard smooth Access Panel.

Consult factory.

### MOUNTING STANCHION

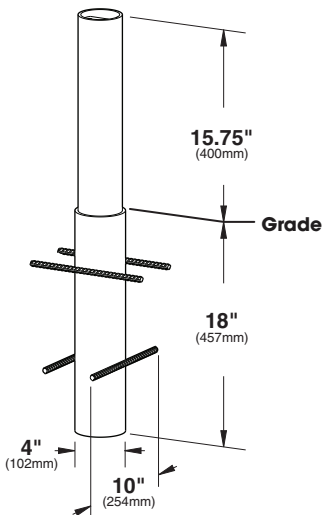

3½" SCH40 STEEL PIPE (below grade) WELDED TO 3" SCH 40 STEEL PIPE (above grade). (4) SECTIONS OF REINFORCING BAR WELDED TO LOWER PIPE FOR TIE-IN TO PAVING AND FOOTING STEEL BY OTHERS. ENTIRE ASSEMBLY IS HOT DIPPED GALVANIZED.

### LED® MODULES

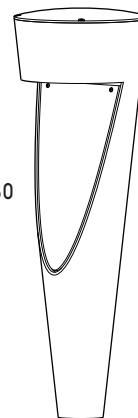

**TNA** E.P.A.= 1.30  
Available in:  
24 LED Module

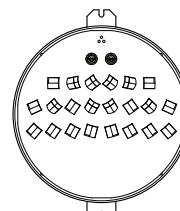

24 LED Module

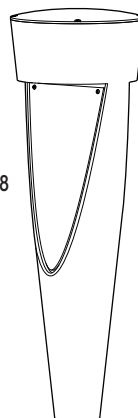

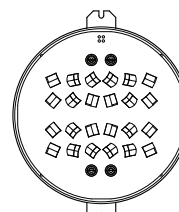

**TNS** E.P.A.= 1.18  
Available in:  
28 LED Module



28 LED Module

## O R D E R I N G I N F O R M A T I O N

LUMINAIRE	OPTICS	# of LED's	COLOR	VOLTAGE	FINISH	OPTIONS
<b>LUMINAIRE</b>	<b>OPTICS</b>	<b>LED</b>	<b>FINISH</b>	<b>OPTIONS</b>		
<p>LUMINAIRE</p> <p><input type="checkbox"/> <b>TNA-LED</b></p> <p><input type="checkbox"/> TNS-LED</p>	<p>LED® DISTRIBUTION TYPE</p> <p>TNA</p> <p><input type="checkbox"/> ASY ..... </p> <p>TNS</p> <p><input type="checkbox"/> SYM ..... </p>	<p>No. LEDs</p> <p>TNA</p> <p><input type="checkbox"/> <b>24LED</b> (28 Watts)</p> <p>TNS</p> <p><input type="checkbox"/> <b>28LED</b> (32 Watts)</p> <p>Wattages are Max Input Watts</p>	<p>COLOR</p> <p><input type="checkbox"/> NW (4000K)* *STANDARD</p> <p><input type="checkbox"/> CW (5000K)</p> <p><input type="checkbox"/> <b>WW (3000K)</b></p> <p>OTHER LED COLORS AVAILABLE CONSULT FACTORY</p>	<p>VOLTAGE</p> <p><input type="checkbox"/> <b>120</b></p> <p><input type="checkbox"/> 208</p> <p><input type="checkbox"/> 240</p> <p><input type="checkbox"/> 277</p> <p><input type="checkbox"/> 347</p> <p><input type="checkbox"/> 480</p>	<p>STANDARD TEXTURED FINISH</p> <p><input type="checkbox"/> BLACK RAL-9005-T</p> <p><input type="checkbox"/> WHITE RAL-9003-T</p> <p><input type="checkbox"/> GREY RAL-7004-T</p> <p><input type="checkbox"/> DARK BRONZE RAL-8019-T</p> <p><input type="checkbox"/> GREEN RAL-6005-T</p> <p>FOR SMOOTH FINISH REMOVE SUFFIX "T" (EXAMPLE: RAL-9500)</p> <p>SEE USALTG.COM FOR ADDITIONAL COLORS</p>	<p>OPTIONS</p> <p><input type="checkbox"/> RAISED ACCESS - PANEL ..... RAP</p> <p><input type="checkbox"/> DIMMABLE DRIVER(S) (0-10V) ..... DIM</p> <p><input type="checkbox"/> HIGH-LOW DIMMING FOR HARDWIRED SWITCHING OR NON-INTEGRATED MOTION SENSOR ..... HLSW</p> <p><input type="checkbox"/> 10KV SURGE PROTECTOR ..... 10SP</p> <p><input type="checkbox"/> 20KV SURGE PROTECTOR (277V &amp; 480V Only) ..... 20SP</p>

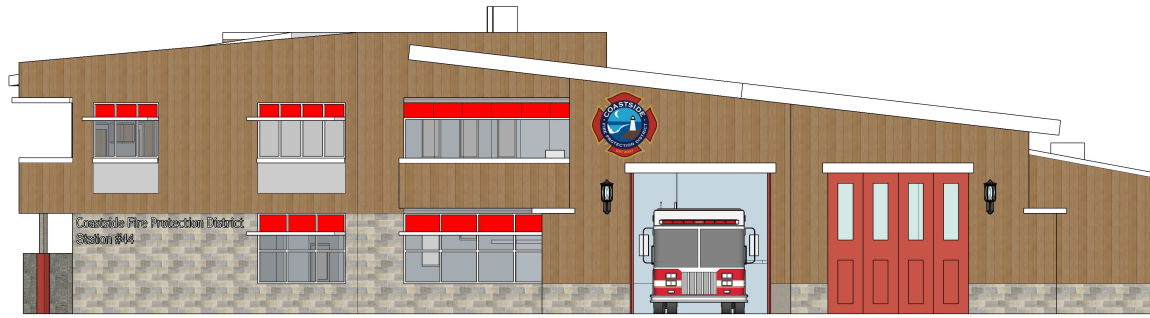

STATION IDENTIFICATION:



EXTERIOR STYLES/COLORS



VERTICAL PLANK SIDING  
NICHIIA VINTAGEWOOD  
CEDAR



WINDOW PANELS  
JAMES HARDIE  
LIGHT MIST

PAINT COLORS



TRIM  
BENJAMIN MOORE  
CHANTILLY LACE  
OC-65

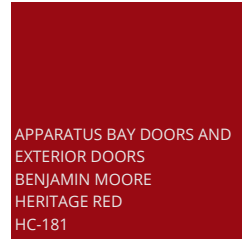

APPARATUS BAY DOORS AND  
EXTERIOR DOORS  
BENJAMIN MOORE  
HERITAGE RED  
HC-181

SPANDREL COLOR



RAL 3002  
CARMINE RED

PRODUCT INSPIRATION



REFLECTION BRICK®  
MASONRY UNITS  
ENCHANTMENT

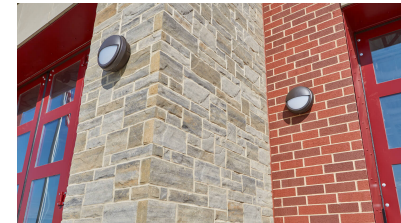

COASTSIDE FIRESTATION #44 - EXTERIOR FINISHES

FINISHES SELECTED ON

APPROVED ON:







COUNTY OF SAN MATEO - PLANNING AND BUILDING DEPARTMENT

# ATTACHMENT B

# Midcoast Community Council

*An elected Advisory Council to the San Mateo County Board of Supervisors  
representing Montara, Moss Beach, El Granada, Princeton, and Miramar*  
PO Box 248, Moss Beach, CA 94038-0248 | [midcoastcommunitycouncil.org](http://midcoastcommunitycouncil.org)

**Gus Mattammal** | **Gregg Dieguez** | **Scott Bollinger** | **Ann Rothman** | **Dan Haggerty**  
Chair Vice-Chair Treasurer Secretary  
**Claire Toutant**  
**Kimberly Williams**

Date: June 12, 2024

To: Glenn Jia, Planner III & Design Review Officer, County of San Mateo  
cc: Supvr. Ray Mueller, Gina Quiney, Marisol Escalera Durani, CFPD Board  
From: Midcoast Community Council  
Subject: Unresolved Concerns re: Proposed Moss Beach Fire Station (PLN2023-0031)

Dear Mr. Jia,

The MCC remains concerned about both process and content issues relating to this project, which haven't been fully addressed by the applicant for PLN2023-0031, Fire Station 44, Moss Beach. From a process perspective, we are disappointed that our requests for information regarding lighting and other concerns weren't addressed until Monday 6/10, leaving us only 48 hours to read, digest, and respond to the information. Further, we have never received a response to our request for specific information to understand the decision process that led to the choice of the site for Station 44. Spending taxpayer money requires a transparent process, including consideration of the alternative of selling the current site land, while moving to another location and avoiding the time and expense of a temporary station. Given the sizable amount of taxpayer money involved, the community does have a right to understand the decision processes that led to the current project plan.

From a project content perspective, we continue to have concerns about the variances requested because the proposed fire station does not comply with the residential zoning in which it is located. The Planning Department's original comments stated that the fire station should comply with the 20 foot setbacks, 28 ft. height, and 6,200 square foot maximum floor space. The MCC agrees with this assessment. Furthermore, when PBK Architects first presented this project to the community it was stated that the footprint would comply with these standards.

The hazards that neighbors will face due to the oversized design cannot be mitigated without moving the bay to the center of the property or to a more suitable lot. The shape of this lot and its relationship to adjoining streets and residences do not allow for the same sort of design that worked at Station 41, or at other sites. Most drive-through fire

stations sit at a corner of two streets to enter on one side and exit from the other and do not share property lines with residences as Moss Beach Station 44 does. Because the entrance and exit for this project are on the same street, it requires a tight turning radius to use the drive through feature, restricting the size of apparatus that can be stored at this location. The tight turning radius increases the potential for a collision with the on-site diesel generator, fueling station, and storage that is proposed to be located next to four homes.

The current plan for the apparatus bay is right on the property line next to the greatest number of homes. This presents immediate and lasting hazards to the surrounding homes such as diesel fumes that are known to be carcinogenic from the fire truck exhaust, diesel generator and diesel fuel storage and refueling centers. The proposed decontamination area for fire trucks and hazmat materials will take place in the back of the bay which sits right next to homes. Aerosolized particles of contaminants can easily enter open windows. Extremely loud sound from running fire trucks, sirens, and the tones used to send trucks out of the station, will be right next to neighbors in this design. The decibel level of a running diesel truck is about 100 dB. At 100dB hearing loss can occur in 15 minutes of exposure. Sirens can be as high as 120 dB causing hearing loss and pain in under 2 minutes. An acceptable level of sound for most residential areas are 50-60 decibels. A quiet home averages 40dB.

The MCC has asked what decibel levels are emitted from the fire trucks, exhaust system, and the diesel generator. If firefighters wear hearing protection due to the many sound hazards, what are neighbors supposed to do? This is a hazard that only distance from the source can solve. For example, in order to reach an acceptable level of 55-60 decibels for most residential areas, an idling diesel truck needs to be 1,600 feet away. The bay of the current fire station is situated in the middle of the property and the distance helps mitigate truck noise. The proposed firehouse bay needs to remain an adequate distance from neighbors to similarly minimize noise disturbances.

San Mateo County lists the following standards for sound and odor in areas zoned for industrial use. If these standards are required for industrial safety, shouldn't they be as stringent or more so in a residential neighborhood?

**SECTION 6289.1. PERFORMANCE STANDARDS.** No use may be conducted in a manner which, in the determination of the Planning Director, does not meet the performance standards below. Measurement, observation, or other means of determination shall be made at the limits of the property, unless otherwise specified.

1. Noise. No use will be permitted which exceeds the noise levels established in Section 4.88.330 in the County Ordinance Code:

	Level (in dBA) Not To Be Exceeded
--	-----------------------------------

Time of Day	More Than 30 Minutes In Any Hour	More Than 5 Minutes In Any Hour	At Any Moment
7:00 a.m. - 10:00 p.m.	60	70	80
10:00 p.m. - 7:00 a.m.	55	65	75

2. Odor. No use will be permitted which emits an odor or air pollutant, detectable without instruments, beyond the boundaries of the "Waterfront" District.

The MCC continues to be concerned about the impacts of excessive lighting for environmental and health reasons that are well-documented and about which the American Medical Association has also expressed serious concern. We appreciate the opportunity to review the details of the updated lighting plan. We note that only one light option highlighted, seems to be Dark Sky International compliant. The other options presented have some helpful features such as directing light downward and limiting the spillover radius, but these appear to utilize high blue light levels rather than warm light, and the glow and reflection could still illuminate the surrounding area. It would be helpful to have a lighting technical expert who is knowledgeable about the lighting options presented in the updated plan and also knowledgeable about the Dark Sky International guidelines, further explain the current lighting options and how these will function on the ground in real time.

Moreover, erecting story poles prior to planning commission actions should be required for the proposed fire house as well as for any lighting poles and fixtures of significant size and height.

The MCC reiterates our request for a list of the other site alternatives that were evaluated and an explanation of the evaluation criteria and methods used for each of the other locations. We understand that cost was a factor. It would be helpful for the community to understand the evaluation measures and options that were considered to inform the current site choice.

We also continue to be concerned about the ability of emergency vehicles to navigate the narrow, congested and often poorly-maintained roadways surrounding the station, especially in light of planned construction for a neighboring housing development.

Given the number of problems this vital community resource faces in being a good neighbor in a relatively isolated neighborhood several blocks from the highway, we feel that a better site is crucial to the long-term safety of the area, and would be a better

long-term investment overall. The fact that the proposed temporary station avoids all of the problems we've identified, underscores that this option or a similar alternative is a possibility that should continue to be pursued.

Sincerely,

Gus Mattammal, Chair  
Midcoast Community Council



COUNTY OF SAN MATEO - PLANNING AND BUILDING DEPARTMENT

# ATTACHMENT C

1327 Archer Street  
Suite 110  
San Luis Obispo, California 93401  
Phone: 805-329-3076  
PBK.com

6/10/2024

VIA: Email



**Attn: San Mateo Planning Department**

**Re: Planning Re-submittal, Response Letter**

COMMENT: Suggested changing the upper floor white sidings/paint to earth-tone, non-reflective colors/materials.

RESPONSE: See updated exhibit with updated exterior materials. The exterior colors have been revised to eliminate the white siding and feature more of an earth tone scheme.

COMMENT: Requested additional information, such as lighting specs and updated lighting plan

RESPONSE: See updated light plan (E1.1P) and data fixture sheets.

COMMENT: Suggested relocation of the apparatus bays to the north side to reduce impacts on denser south side.

RESPONSE: This comment would be impactful to the overall design of the project, especially the return/response drive design.

1. Return Drive & Public Safety – Due to the shape of the site, if the apparatus bays are relocated to the north side, we won't have the space required to accommodate a return driveway around the back of the station. The return driveway is a critical component to the design of a modern fire station and provides a benefit to the community and public safety. It allows for an efficient return to the station without needing to block the street to back-in as they currently do. This allows for better visibility, reduces the potential for an accident in front of the station, and gets trucks off the street more efficiently with more preparation time for the next response. If the return driveway is removed, backing into the station would be required which happens at a higher decibel level, and if a significant earthquake or other disaster were to occur apparatus could block access to the site.
2. Functionality – If we were to shift the building behind the front setback, it would put a huge strain on the ability of the station to function in an ideal capacity. In addition to losing the return driveway, the station would lose multiple staff parking stalls, and no longer be able to fit all staff vehicles on site. The rear work yard would be negatively impacted, reducing the effectiveness of the staff on site to prepare and respond.

**COMMENT:** Concerned with hazardous fumes from hazmat equipment and engine emission

**RESPONSE:** The new station will be an improvement from the existing situation. First, the new engines for this station use a def-system, known as clean diesel, lower emissions. Secondly, the drive-thru return feature improves emissions as well. Engines have lower emissions when idling through a return vs. accelerating back and up into a bay.

**COMMENT:** Public health concerns related to noise and lighting.

**RESPONSE:**

1. Lighting - Very careful attention has been given to the lighting design of this station. The feedback received from MCC was understandable and has influenced our redesign. Please reference the updated site lighting plan on sheet E1.1P. The intent of the Fire District is to blend in with existing conditions and avoid any harsh light that would disturb neighbors and wildlife as noted by the MCC, while still meeting at least the minimum lighting requirements needed to safely light the site. Our updated design includes lighting fixtures mounted on the retaining walls preventing light from spilling over into the neighboring houses. However, in the case of an emergency it is vital that the fire station has the proper lighting to help ensure the community is safe. We included pole mounted lights in the back to ensure that the station is properly lit during an emergency. The emergency lighting will be on a key system and only be activated during emergencies. Please understand that the site lights have been reduced to minimize light spill with the wall mounted lights. Also, the light to the left of the response drive has been removed and replaced with a light bollard.
2. Noise - The apparatus bay will be exhausted with an inline fan that will be mounted in the attic space of the building and ducted up through the roof. The advantage of this approach is that the motor will be internal to the building and any noise from the exhaust motor will be captured within the attic space and will not be noticeable by the community. The exhaust fan will run when trucks return to the apparatus bay to remove contaminants from the air and preserve a healthy workspace for the fire fighters.

Construction noise / pollution mitigation: As part of the building permit submittal, our technical specifications will clearly describe the precautions that must be taken during construction to minimize hazards / pollution / noise within and around the job site. Typical remedies include monitoring jobsite noise levels, specifying allowable work hours during daytime, alerting the neighborhood ahead of any noisy activities, use of quiet machinery, Dust control, fencing, and sound barriers.

**COMMENT:** Suggested that the CFPD erect sound walls for noise reduction.

**RESPONSE:** The current design has effectively addressed the issue of noise pollution on site in comparison to the existing station. One major improvement lies in the addition of the return drive, which has eradicated the need for engines to emit loud alerting beeps while reversing. This alteration has significantly reduced noise levels in the vicinity. Furthermore, the installation of exhaust fans with inline motors has contained noise within the building walls, thus preventing external disturbances. The addition of 15-foot-high retaining walls has also played a crucial role in



minimizing sound transmission from trucks, generators, and crew working in the back area, a feature that is absent at the current site.

**COMMENT:** The proposed perm. Station is too big (3x existing).

**RESPONSE:** The fire station as sized is required to provide a facility that is equipped to serve the community and accommodate the health, safety, and wellness standards for the fire fighters necessary in a modern fire house. By including features such as individual bedrooms, fitness room, kitchen/dining, and dayroom spaces, the fire station not only promotes the health and wellness of its personnel, but also creates a supportive and engaging environment. A smaller station would impact response times and compromise firefighter safety and wellness. Ultimately, the goal is to provide excellent service for the community, and a modern fire station is necessary to achieve that.

**COMMENT:** Suggested that the perm. Station be moved to the site for the temp. station and demanded an alternative site analysis from CFPD.

**RESPONSE:** The fire protection board assigned staff to investigate the availability of alternative sites for acquisition, but after thorough research, it was concluded that no other options were viable. CFPD Division Chief Gary Silva canvassed the community surrounding the site and found widespread support for reconstructing the station at the current site. Additionally, the District explored the possibility of siting the new station at the temporary facility site and found doing so would be impractical and financially infeasible due to land acquisition costs and extensive land use changes that would be required. Therefore, it was decided that the current site is the most suitable option.

**COMMENT:** Suggested that the contractors of CFPD to coordinate with Cypress Point contractors due to their adjacency (to avoid traffic...)

**RESPONSE:** If construction overlaps on these projects, we will do our best to coordinate with the Cypress Point contractors and keep in consideration the possibility of increased traffic in the area. This will be noted in the project specifications.

**COMMENT:** CFPD is still working on a revised lighting plan and preparing response to some of the comments above. For these reasons, MCC requested that the 6/26 PC hearing be postponed.

**RESPONSE:** We would like to keep the schedule as planned and proceed with the PC hearing on 6/26.