

Final



Crystal Springs Dam Bridge Replacement Project Restoration, Monitoring, and Reporting Plan

Final

Crystal Springs Dam Bridge Replacement Project

Restoration, Monitoring, and Reporting Plan

County Bridge No. 67/State Bridge No. 35C-0043 Skyline Boulevard Over the
Lower Crystal Springs Dam

August 31, 2011

Prepared for



County of San Mateo, Department of Public Works
555 County Center, 5th Floor, Redwood City, CA 94063-1665
Tel 650.363.4100 Fax 650.361.8220

Prepared by

Cardno ENTRIX
2300 Clayton Road, Suite 200, Concord, CA 94520
Tel 925 935 9920 Fax 925 935 5368 Toll-free 800 368 7511
www.cardnoentrix.com

Table of Contents

Chapter 1	Introduction.....	1-1
1.1	Project Background.....	1-1
1.2	Goals and Objectives	1-5
1.2.1	Revegetation Implementation and Monitoring	1-5
Chapter 2	Existing Conditions	2-1
2.1	Vegetation.....	2-1
2.2	Soils	2-5
Chapter 3	Site Preparation	3-1
3.1	Equipment Cleaning	3-1
3.1.1	Sudden Oak Death Syndrome	3-1
3.2	Soil Preparation.....	3-2
3.2.1	Soil Amendments.....	3-2
3.2.2	Erosion Control.....	3-2
3.3	Plant Installation Guidelines.....	3-2
3.3.1	Plant Spacing	3-3
3.3.2	Planting.....	3-3
3.3.3	Protection.....	3-4
3.4	Irrigation Plan	3-4
Chapter 4	Implementation Schedule.....	4-1
Chapter 5	Maintenance, Monitoring and Success Criteria	5-1
5.1	Maintenance.....	5-1
5.2	Monitoring Methods	5-2
5.2.1	Tree Survival	5-2
5.2.2	Photo-Documentation	5-2
5.3	Success Criteria.....	5-2
5.3.1	Adaptive Management.....	5-2

Chapter 6 Reporting.....6-1

Chapter 7 References7-1

Tables

Table 3-1 Plant Spacing for Tree Species 3-3
Table 5-1 Success Criteria for Planted Species..... 5-2

Figures

Figure 1-1 Project Vicinity and Construction Site 1-3
Figure 2-1 Existing Tree Locations 2-3

Acronyms

APE	Area of Potential Effect
BAAQMD	Bay Area Air Quality Management District
BMPs	best management practices
Caltrans	California Department of Transportation
CARB	California Air Resources Board
CDFG	California Department of Fish and Game
CEQA	California Environmental Quality Act
CNDDDB	California Natural Diversity Data Base
CNEL	Community Noise Equivalent Level
ESA	Environmentally Sensitive Area
HBRRP	Highway Bridge Replacement and Rehabilitation Program
HCAS	Historic Context and Archaeological Survey Report
HPSR	Historic Property Survey Report
I-280	Interstate 280
MCE	Maximum Credible Earthquake
mph	miles per hour
NRHP	National Register of Historic Places
PM ₁₀	particulate matter less than 10 microns in diameter
PM _{2.5}	particulate matter less than 2.5 microns in diameter
PMF	Probable Maximum Flood

PRC	Public Resources Code
RMRP	Restoration, Monitoring, and Reporting Plan
SFBAAB	San Francisco Bay Area Air Basin
SFPUC	San Francisco Public Utilities Commission
SHPO	State Historic Preservation Officer
SWPPP	Stormwater Pollution Prevention Plan
USA	Underground Service Alert
USACE	U.S. Army Corps of Engineers
USFWS	U.S. Fish and Wildlife Service
WSIP	Water System Improvement Program

This Page Intentionally Left Blank

Chapter 1

Introduction

This Restoration, Mitigation, and Monitoring Plan describes the County of San Mateo's (County) approach to restoring the areas that will be disturbed during the planned reconstruction of a new, seismically sound, Crystal Springs Dam Bridge that will be situated atop the Lower Crystal Springs Dam. This Project will result in disturbance to existing vegetation along either side of Skyline Boulevard. The plan includes re-vegetating disturbed upland areas with native trees. The plan also includes subsequent monitoring to identify maintenance needs and ensure that the planted areas achieve prescribed performance criteria.

***Mitigation Measure BIO-12:** The County will develop a Restoration, Monitoring, and Reporting Plan (RMRP) prior to Project implementation. The RMRP will provide details of restoration and enhancement activities, monitoring, and reporting. RMRP elements will include identification of the areas in which restoration will occur, specifics on removal of any existing vegetation that must be accomplished, details of site preparation, species and sizes of material to be planted, irrigation options as needed, performance criteria, frequency and duration of monitoring, reporting requirements, and interventions to be implemented if performance criteria are not met.*

1.1 Project Background

The Crystal Springs Dam Bridge (County Bridge Number 67) was constructed in 1924 as part of State Route 35 and is situated on an easement over the top of the Lower Crystal Springs Dam, owned by the San Francisco Public Utilities Commission (SFPUC). When Interstate 280 (I-280) was completed in 1971, the California Department of Transportation (Caltrans) relinquished the highway right-of-way for use as a San Mateo County highway, and the bridge easement was conveyed to the County. The County highway across the bridge is Skyline Boulevard. The Project vicinity and Project construction site are shown in Figure 1-1.

In 1986, the bridge was analyzed and found to be structurally incapable of withstanding the Maximum Credible Earthquake (MCE) for the area (Nolte and Associates, Inc. 1994). A condition assessment done in 2002 revealed that the bridge was estimated to have six to ten years of remaining life (Parsons Brinckerhoff Quade & Douglas, Inc. 2002). Both 2007 and 2008 Caltrans bridge inspection reports noted that, due to its overall condition, the bridge should be replaced. (Caltrans 2008a).

Continued use of the bridge and vibration from vehicles passing over the bridge are expected to worsen these conditions, and could potentially lead to failure of portions of the bridge over time.

The SFPUC designed a project that would contain the Probable Maximum Flood (PMF) for the Crystal Springs Reservoir. The SFPUC's project would increase the height of the parapet wall on

the reservoir side of the dam by 9.5 feet. This increased height, however, would not fit underneath the existing bridge. The proposed Project and SFPUC Lower Crystal Springs Dam Improvements Project have separate funding and separate objectives, and would be implemented regardless of plans for the other project. However, the close proximity of the two projects in time and location allows some coordination of engineering design. As a result of the design coordination, the profile of the new bridge will be raised to accommodate the new height of the dam's parapet wall. The bridge construction schedule will stagger construction of the two projects such that dam improvements can be constructed after demolition of the existing bridge and before construction of the new bridge. The San Francisco Planning Commission certified the final EIR for the Lower Crystal Springs Dam Improvements Project on October 7, 2010.

The proposed Project will result in the replacement of the existing bridge with a new concrete and steel-reinforced bridge. The new 51.5-foot-wide, 612.5-foot-long bridge will replace the existing 33-foot-wide, 608-foot-long bridge. This bridge will be approximately 18.5 feet wider than the existing bridge and will overhang the dam more than the existing bridge. The demolition of the existing bridge is expected to take approximately 6 months. The SFPUC project is expected to take approximately 18 to 24 months, and construction of the new bridge is expected to take approximately 12 months.

The new bridge will be approximately 7 feet higher than the existing bridge to accommodate the height of SFPUC's new parapet wall with a clearance under the bridge of approximately 1 to 2 feet. The roadway to the north and south of the new bridge (i.e., Skyline Boulevard) will be slightly re-contoured to meet the profile of the new bridge. This will be accomplished by raising the grade of Skyline Boulevard at both the north and south ends of the bridge by approximately 7 feet. Since the road climbs in elevation at each end of the bridge as the road extends away from the bridge, the raised grade will taper off at further distances from the bridge. The raised grade of the road will extend for approximately 500 feet from the bridge on both the north and south ends.

Construction activities, grading and filling, and staging of construction equipment associated with the proposed Project will result in disturbance on and immediately adjacent to the bridge replacement site. The maximum area that could be disturbed during construction will be approximately 80 feet wide and 1,650 feet long, or approximately 2.04 acres. Approximately 58,000 square feet (1.33 acres) of the roadway approach area will be exposed to disturbance from construction activities. These activities will result in ground disturbance, and some of the area affected by this disturbance will require vegetation removal. All construction equipment and vehicle staging will be confined to construction areas.



Source: ENTRIX, Inc. 2008

Crystal Springs Dam Bridge Replacement Project

Figure 1-1

Project Vicinity and Construction Site

Before completing these major construction components, the County's bridge construction contractor will:

- Clear brush and trees to permit construction equipment access to the site;
- Clear brush and trees to prepare for staging activities on both sides of the bridge;
- Excavate and grade in preparation for installation of the bridge abutments; and
- Grade and fill to bring the roadway approaches up to the grade of the new bridge.

1.2 Goals and Objectives

The specific goals and objectives of this plan include restoration of areas from which trees are removed for temporary construction use, replacement of trees removed that are greater than 12 inches in diameter at 4.5 feet from the ground surface, and monitoring of the plantings.

1.2.1 Revegetation Implementation and Monitoring

The goal of this element is to revegetate disturbed areas with locally acquired sources of native seeds and plants in a manner that is not likely to adversely affect listed species and will return the site to at least its pre-existing condition or better. The revegetated areas will be monitored by the County or the County's contractor over a period of three years to determine the success of the planting and to evaluate whether additional plantings by the County are needed to meet the prescribed success criteria. If all success criteria are met, no further monitoring will be conducted. If survival rates in either of the first two years are low enough that the three-year success criteria are unlikely to be met, additional plantings will be made, and monitoring will occur for another two years, for a total of five years of monitoring.

This Page Intentionally Left Blank

Chapter 2

Existing Conditions

2.1 Vegetation

The bridge structure is located directly above the Lower Crystal Springs Dam. The roadway re-contouring, bridge replacement, and parking access adjustment work will occur entirely within the County's Skyline Boulevard roadway right-of-way and a portion of the SFPUC's right-of-way at the Scenic Vista Point parking area. The site is bordered by SFPUC property to the east and west with the Crystal Springs Reservoir adjacent to the west side of the Project area. The Project is approximately 1,650 linear feet in length.

The biological habitat at the site is Mixed Evergreen Forest Vegetation on the upper slopes adjacent to the existing bridge abutments. Within the Project vicinity, this community is generally composed of a pronounced hardwood tree layer, with a poorly developed shrub stratum, and a sparse herbaceous layer. Common species include coast live oak (*Quercus agrifolia*), Douglas fir (*Pseudotsuga menziesii*), madrone (*Arbutus menziesii*), and California bay (*Umbellularia californica*). This vegetation type also includes other trees, such as Monterey pine (*Pinus radiata*) and Monterey cypress (*Cupressus macrocarpa*), which are not native to the area. It is presumed that these and some of the other non-native plants on the site were introduced at the time the dam was originally constructed. Typical shrubs in this area are poison oak (*Toxicodendron diversilobum*), toyon (*Heteromeles arbutifolia*), and blackberry (*Rubus* spp.). Understory herbaceous plants occur in open spots in the Mixed Evergreen Forest, especially near the existing abutments. Along the north abutment, there is a dense thicket of poison oak, toyon, and Australian tea tree (*Leptospermum laevigatum*).

A tree survey was conducted in the Project impact area on June 25, 2008, and the results of this survey were included in the Initial Study with Proposed Mitigated Negative Declaration (ENTRIX, 2009). That survey determined that approximately 35 Significant Trees (defined as trees greater than 12-inch diameter at breast height pursuant to Section 12, 012 of the County Significant Tree Ordinance) might require removal; of these, 27 are oak trees, native to the area. None of these trees constitute "heritage trees" under the San Mateo County Heritage Tree Ordinance due to their type and/or size (San Mateo County Ordinance, Section 1100, Ordinance No. 2427, 1977).

Tree species observed included coast live oak, canyon live oak (*Quercus chrysolepis*), unspecified live oaks (*Quercus* spp.), California bay (*Umbellularia californica*), toyon, Oregon ash (*Fraxinus latifolia*), cypress (*Cupressus* sp.), Monterey pine (*Pinus radiata*), and acacia (*Acacia* sp.). Species and size for inaccessible trees were estimated. Trees on slopes that will be cut or filled for the Project are included in the count.

Excavation, grading, and associated disturbance during demolition of the existing bridge and construction of the proposed new bridge will result in the removal and/or potential disturbance of

vegetation on either side of the bridge. Potential impacts will be limited to small unpaved areas on the sides of Skyline Boulevard within the roadway right-of-way. Less than 1.0 acre will be exposed to this type of disturbance and potential vegetation removal. Construction activities will result in the removal of Monterey pines, Monterey cypress, and several coastal live oaks. None of these trees constitute “heritage trees” under the San Mateo County Heritage Tree Ordinance due to their type and/or size (San Mateo County Ordinance, Section 1100, Ordinance No. 2427, 1977).

A follow-up survey was conducted on August 5, 2010, after design drawings had been further refined. The results of that survey indicated that only twenty-three (23) Significant Trees (defined as trees greater than 12-inch diameter at breast height pursuant to Section 12, 012 of the County Significant Tree Ordinance) will require removal. Thirty (30) trees between 4 inches and 12 inches DBH will be removed (Figure 2-1).

Between the intersection of Crystal Springs Road with Skyline Boulevard and the north end of the bridge, project construction will result in the removal of trees on both sides of the road. South of the bridge, project construction will result only in the removal of a single large Monterey pine.

An alternative design for the northern approach would include retaining walls constructed near the top of the slope for a portion of either side of the approach, rather than regrading the full length of each slope to its base. This would reduce the number of trees to be removed and replaced.

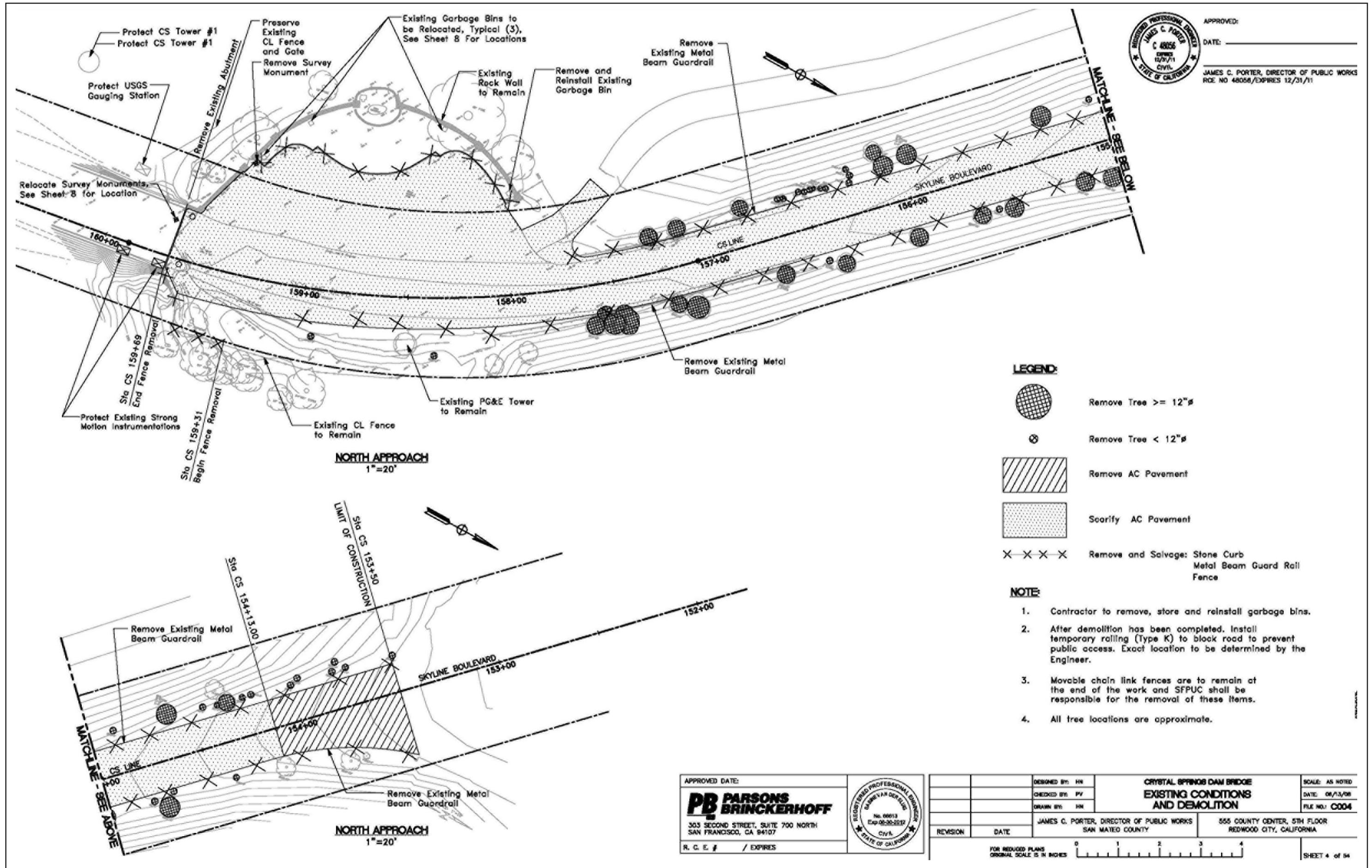





Crystal Springs Dam Bridge Replacement Project

Figure 2-1
Existing Tree Locations



APPROVED: _____
DATE: _____
JAMES C. PORTER, DIRECTOR OF PUBLIC WORKS
RCE NO 48056/EXPIRES 12/31/11

LEGEND:

-  Remove Tree >= 12"φ
-  Remove Tree < 12"φ
-  Remove AC Pavement
-  Scarify AC Pavement
-  Remove and Salvage: Stone Curb
Metal Beam Guard Rail
Fence

NOTE:

1. Contractor to remove, store and reinstall garbage bins.
2. After demolition has been completed. Install temporary rolling (Type K) to block road to prevent public access. Exact location to be determined by the Engineer.
3. Movable chain link fences are to remain at the end of the work and SFPUC shall be responsible for the removal of these items.
4. All tree locations are approximate.

APPROVED DATE: _____
PB PARSONS BRINCKERHOFF
 303 SECOND STREET, SUITE 700 NORTH
 SAN FRANCISCO, CA 94107
 R. C. E. # / EXPIRES _____

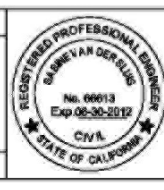

DESIGNED BY: HN	CRYSTAL SPRINGS DAM BRIDGE EXISTING CONDITIONS AND DEMOLITION	SCALE: AS NOTED
CHECKED BY: PV		DATE: 06/13/08
DRAWN BY: HN		FILE NO: C004
JAMES C. PORTER, DIRECTOR OF PUBLIC WORKS SAN MATEO COUNTY		555 COUNTY CENTER, 5TH FLOOR REDWOOD CITY, CALIFORNIA
REVISION	DATE	



2.2 Soils

The Project is located on Franciscan Complex, a mixture of marine sedimentary rocks and volcanic rocks subject to repeated geologic deformation. The predominant bedrock type at the dam and bridge abutments is greywacke, a fine-grained, well-cemented sandstone containing some shale. Fill was placed behind both existing bridge abutments in 1923. The fill has been in place for 68 years and appears to be well compacted (Wahler & Associates 1992).

Soil types in the Project footprint are Fagan loam (15 to 50 percent slopes), Los Gatos loam (30 to 75 percent slopes), and Obispo clay (15 to 30 percent slopes (USDA-NRCS 1991). The Fagan series is a deep, well-drained soil on uplands. The Los Gatos series is a moderately deep, well-drained soil on uplands. Permeability is slow for both of these soils, with rapid to very rapid runoff, and the hazard of water erosion is high to very high. Fagan soils are susceptible to slippage when it is wet, especially in the steeper areas. The Obispo series is a shallow, well-drained soil on uplands. Permeability is slow for Obispo soils, with rapid runoff, and the hazard of water erosion is moderate. Most of the project footprint is in Los Gatos loam soil, but the footprint extends into Fagan loam at the north end and Obispo clay at the south end.

This Page Intentionally Left Blank

Chapter 3

Site Preparation

Site preparation includes vegetation removal, soil preparation, planting, and irrigation. In addition, due to the potential for invasive species to affect the survival of revegetation plantings and the presence of a pathogen in the Project area, this section also includes specifications for equipment cleaning.

3.1 Equipment Cleaning

3.1.1 Sudden Oak Death Syndrome

Sudden Oak Death Syndrome has been detected in trees on the perimeter of Upper and Lower Crystal Springs Reservoirs. Host plants for this disease include coast live oak and California bay. Individuals of both of these species are scheduled for removal at the Project site. The California Oak Mortality Task Force has compiled Best Management Practices for a variety of activities, including forestry (COMTF 2010a). The following measures have been adapted from the Forestry BMPs and will be implemented during removal of trees and other vegetation. Once the trees and their litter are removed, these BMPs will no longer be necessary.

- The Environmental Monitor will inform personnel that they are working in an area with Sudden Oak Death disease, unauthorized movement of plant material is prohibited, and the intent of mitigation measures is to prevent disease spread (14 CCR 1035.2).
- The County or its contractor will ensure that all off-road equipment brought into the area from outside the watershed is free of soil, seeds, vegetative material, or other debris that could carry Sudden Oak Death Syndrome or could contain or hold seeds of invasive weeds. Off-road equipment includes all logging, construction, and brushing machinery/equipment (brush hogs, masticators, and chippers) except log trucks, chip vans, service vehicles, water trucks, pickup trucks, and similar vehicles not intended for off-road use. Equipment in this category (e.g., excavators and dozers) is generally rented and brought to the job site by a contractor hired by the County.
- Each time equipment or vehicles leave the site during the vegetation removal activities, the equipment or vehicles will be inspected by a County representative for host plant debris (leaves, twigs, and branches). Host plant debris will be removed from equipment and vehicles prior to their departure. This applies to all equipment and vehicles associated with the operation, including, but not limited to, logging equipment, log-hauling trucks, pick-up trucks, and employee's personal vehicles. An exception will be granted for equipment or vehicles that leave the site temporarily and will not be traveling to infested areas prior to their return.

3.2 Soil Preparation

Site preparation may include the scarification of surface soils to reduce soil compaction and provide a suitable seedbed, where topsoil salvage has not been implemented. If a site is compacted, the upper 24 inches of soil will be decompacted, to the extent feasible on the relatively steep slopes of the Project site. Decomposition may be accomplished by ripping or harrowing so that vegetative growth is not inhibited. Small areas may be raked by hand. Due to the steepness of the slopes at this site, topsoil salvage is not proposed.

Final grading and harrowing of the topsoil and subsoil at the site prior to planting will be along the contours to slow runoff and prevent soil transport. Once the soil is placed, it will be lightly scarified or raked to prepare for seeding. The area will be seeded within a few days after topsoil placement to minimize erosion and the potential for invasive weed establishment.

3.2.1 Soil Amendments

The soil may be amended, if needed for soils with insufficient nutrients, by adding compost (composted, not raw). If high carbon sources are used, nitrogen fertilizer may be added to prevent the nutrients in these materials from being broken up by microorganisms, making them unavailable to the plants.

3.2.2 Erosion Control

Erosion control measures installed during construction will be maintained during revegetation. All exposed ground surfaces, including cut-and-fill slopes subject to wind and water erosion and local raveling will be protected with erosion protection measures as described in the SWPPP.

3.3 Plant Installation Guidelines

Pursuant to Section 12, 024 of the County Significant Tree Ordinance, when construction is complete, oak trees (five [5]-gallon-size stock) will be planted in and around the Project impact area or within SFPUC property or elsewhere within San Mateo County to replace those removed at a ratio of 3:1, resulting in no net loss of oak trees. In addition, non-native significant trees will be replaced with native trees (as determined by the Planning Director) also at a ratio of 3:1 (San Mateo County, Section 12000). However, the commonest native tree species at the Project site after oak is California bay, which is a host plant for Sudden Oak Death Syndrome (COMTF 2010b). Therefore, the replacement trees will all be coast live oak. To allow for a 15 percent mortality, a total of 92 oak seedlings/saplings will be planted.

Planting with locally native oak species from locally obtained stock originating will be accomplished using containerized seedlings/saplings at a density and approximate spacing specified by a qualified biologist or landscape architect. Woody species will be planted at least 10 feet back from the edge of Skyline Boulevard and footpaths. At corners and locations where visibility is crucial, the set-back will be greater. A qualified biologist, County representative, or landscape architect will oversee all revegetation activities.

Tables with representative rates and species are provided below.

After seeding and planting with locally native species, the revegetation area will be immediately covered with mulch to protect the soil and seeds from wind and water erosion and to conserve soil moisture. Although the type of mulch may vary, only materials free of invasive weed seeds and other propagules (e.g., rhizomes, runners) will be used. To be effective, mulch will cover nearly the entire planting surface and persist through seed germination. Mulch types include certified weed-free straw, hydromulching, bonded fiber matrix, and erosion control mats. If other mulches are not available, rice straw that is uncertified, but has been tested for absence of weed seeds may be used.

3.3.1 Plant Spacing

Plants spacing should consider the morphologies and growth structures of the individual plants. Recommended spacing for the selected tree, shrub, and grass species is presented in Table 3-1. With close spacing¹, it should be possible to accommodate all the trees at the Project site. However, if a wider spacing is used for some of the trees, or the usable space is limited, it may not be possible to install all of the trees at the Project site. If insufficient space is available for installation of 92 trees in the area disturbed by Project construction, the County will confer with the SFPUC to determine whether the County may install the remainder in the SFPUC's watershed. If this is not feasible, then the additional trees will be installed in elsewhere in San Mateo County. Although one Significant tree is on the south side of the original bridge, there will be insufficient space for any replacement trees in that area. Therefore, all replacement seedlings/saplings installed at the Project site will be placed along Skyline Boulevard between the north end of the bridge and the intersection with Crystal Springs Road.

Table 3-1 Plant Spacing for Tree Species

Genus/Species	Common Name	Use
<i>Quercus agrifolia</i>	Coast live oak	10 to 30 foot spacing.

An alternative design for the northern approach would include the installation of retaining walls near the top of the slope for a portion of either side of the approach, rather than regrading the full length of each slope to its base. This would reduce the number of trees to be replaced and the number of replacement saplings that would be required. Although this approach would also reduce the space available for planting at the Project site, the reduction in the number of trees requiring maintenance and monitoring could make this the more feasible alternative.

3.3.2 Planting

Containerized oaks will be supplied in five-gallon containers and will be planted according to the following procedures:

¹ With all trees on 10-foot centers or with approximately 57 trees on 10-foot centers and 35 trees on 15-foot centers.

- Planting will occur after fall rains begin, providing natural moisture to the site.
- All sites will be scalped of herbaceous vegetation to a 3-foot by 3-foot size before planting.
- A hole wide and deep enough to accommodate the root ball from a 5-gallon pot will be dug.
- Containerized trees will be planted to the exact depths as the trees are grown in the container.
- The location of each planted oak will be recorded and provided to the County on an as-built drawing.

3.3.3 Protection

Containerized oak plantings need protection from tree and ground squirrels. A galvanized 0.75-inch mesh ‘gopher wire’ cage (18 inches tall) (or similar protection) will be placed as a 5-inch cylinder, 6 inches below ground and 12 inches above ground to protect oak tree plantings. These cages will be removed by the County or the County’s contractor at the end of the monitoring period.

3.4 Irrigation Plan

Depending on the species used and the time of planting, temporary irrigation at the bridge site may be necessary for the establishment of seedlings and saplings during the first summer of growth. An irrigation plan will be developed by the County’s contractor and issued as an addendum to this document after final contouring of the bridge site has occurred. The irrigation schedule will be specific to the project area, but such schedules often include monthly watering in the dry season. The irrigation plan will include specifications for supplemental watering during the rainy season if extended dry periods occur. Supplemental watering may be weekly, but ceases when precipitation resumes.

Chapter 4

Implementation Schedule

To maximize plant survival, seeding and tree planting should generally occur between October 1 and January 1 to take advantage of the winter rains and moist soil conditions. If weather conditions preclude planting in that time period, tree planting can be extended into the early spring. Later plantings are likely to require more frequent supplemental watering in the summer.

This Page Intentionally Left Blank

Maintenance, Monitoring and Success Criteria

The County or the County's contractor will conduct revegetation monitoring to evaluate the establishment of the plantings, to assess the need to implement remedial measures, and to evaluate the effectiveness of invasive weed control measures. Revegetation plantings will be monitored annually following planting, with a final observation to be made three years after the final planting. If all success criteria are met, no further monitoring will be conducted. If survival rates in either of the first two years are low enough that the three-year success criteria are unlikely to be met, additional plantings will be made. If, after three years of monitoring, success criteria are not met, remedial measures will be implemented and monitoring will occur for another two years, for a total of five years of monitoring. Remedial measures may include additional soil amendments, as well as replanting by the County or the County's contractor. Additional qualitative monitoring may be conducted on a more frequent basis by the revegetation contractor, but is not required for documenting the attainment of success criteria.

Monitoring efforts will consider the full range of potential problems that can affect a revegetation treatment after initial planting, including: the establishment of invasive weeds; foraging by wildlife; erosion; damage from flooding, windstorm, rain, or other conditions; failure of introduced plants; and drought or excessive rainfall. Field notes and photographs will be collected to document what site conditions were encountered and which mitigation steps were taken to rectify or control identified issues.

5.1 Maintenance

Maintenance will occur concurrently with the monitoring schedule to remove weeds that may impede the growth of the oak seedlings/saplings.

Invasive weeds will be eradicated by hand equipment only and disposed of as waste in such a way as to avoid spread during transport. Protective screens or tubes that have been damaged will be repaired or replaced.

Unauthorized trails that are observed in the revegetation area will be reported to the County.

If the condition of the planted oaks indicates that the natural water supply or the irrigation schedule is not providing adequate water, this condition will be reported to the County. Irrigation will be implemented or adjusted to provide additional water.

The wire protective cages around the trees will be removed by the County or the County's contractor at the end of the monitoring period.

5.2 Monitoring Methods

Monitoring methods will include counting planted seedlings/saplings to determine survival percentages, recording the presence of any volunteer native trees, and photo-documenting the revegetation efforts.

5.2.1 Tree Survival

The species to be planted at revegetation sites is coast live oak. These seedlings/saplings will be counted at the end of each year in the fall. Any native tree species that establish naturally in the revegetation area will also be recorded.

5.2.2 Photo-Documentation

A minimum of four (4) photo points will be set up to include views of the entire revegetation area. Each photo point will be marked by a numbered stake. If necessary, additional photo points may be established to provide full coverage of the revegetation area. These points will be recorded using a GPS device and noted in a photo point chart along with a notation about the directional reading of each photo. A photo point map will be generated to accompany the chart. Photos will be taken once a year and will be included in the annual monitoring report.

5.3 Success Criteria

Success criteria will be based on measurements for planted species. The number of established healthy trees and shrubs at the end of three years after installation, as provided in Table 5-1, will be deemed a success for the revegetation of the site. If additional plants must be installed to replace losses in excess of the criteria, then success will be evaluated after an additional two years of monitoring. Visual indicators of tree health include, but are not limited to, presence of new annual growth, leaf color, little or no evidence of insect infestation, and few or no stunted or irregularly-shaped leaves.

Table 5-1 Success Criteria for Planted Species

Genus/species	Common Name	Plants installed	Established plants	Percentage
<i>Quercus agrifolia</i>	Coast live oak	92	69	75 percent

These success rates will be applied at the end of three years and again at the end of five years to determine if remedial planting will be required to meet overall success of revegetation project.

5.3.1 Adaptive Management

Revegetated areas that do not meet success criteria within three years will be replanted. If site conditions are such that success criteria are not met within five years, then survival rates for the coast live oak will be evaluated to determine if additional plantings are appropriate. If the site

conditions preclude attainment of the initial success criteria, modified success criteria and/or revegetation goals and objectives will be defined by the Director of Public Works.

Chapter 6

Reporting

The County's biologist, representative or contractor will submit annual monitoring reports to the Director of Public Works. The first year's report will include the as-built report, summarize the baseline information, and present the first year monitoring results. Thereafter, annual reports will consist of a summary of information contained in previous reports, as well as a presentation of the current year's results and discussion of any comparisons between years or trends noted.

Annual reports will include, at the minimum, the following information:

- Summary description of the monitoring methods, including data collection and analysis.
- An overview of the revegetation effort, including a general discussion of site conditions, changes since previous report, total native trees, and survival percentages for the planted seedlings/saplings.
- Analysis of success in relation to performance standards (Table 5-1).
- Color photographs of the revegetation areas taken from the same reference points on the ground and standardized with respect to direction, lens type, etc.
- A map of the area with relevant features.
- Copies of all data sheets employed in the data gathering.
- Any corrective actions needed or undertaken (including invasive plant control efforts or replanting).

This Page Intentionally Left Blank

Chapter 7

References

- California Department of Transportation (Caltrans). 2008a. Caltrans Bridge Inspection Report.
- California Oak Mortality Task Force (COMTF). 2010a. Sudden Oak Death guidelines for forestry. Available at: <http://www.suddenoakdeath.org/wp-content/uploads/2010/08/ForestryGuidelines1.pdf>.
- California Oak Mortality Task Force (COMTF). 2010b. Sudden Oak Death guidelines for arborists. Available at: http://www.suddenoakdeath.org/wp-content/uploads/2010/08/landscaper_1-08.pdf.
- ENTRIX, 2009. Crystal Springs Dam Bridge Replacement Project Initial Study with Proposed Mitigated Negative Declaration. Prepared for the County of San Mateo, August 2009.
- Nolte and Associates, Inc. 1994. Lower Crystal Springs Dam Bridge Replacement Project-Status Report For Engineering Services and Preparation of Construction Documents. Prepared by Nolte and Associates, Inc August 31, 1994.
- Parsons Brinckerhoff Quade and Douglas (PBQD). 2002. The Bridge at Crystal Springs Dam, Condition Assessment and Load Rating, Letter Memo of Findings.
- San Mateo County. 2002. San Mateo County Code. Accessed August 2007 online at <http://www.municode.com/Resources/gateway.asp?pid=16029&sid=5>.
- United States Department of Agriculture (USDA). 1991. Soil survey of San Mateo County, eastern part, and San Francisco County, California. Natural Resource Conservation Service. May.
- Wahler & Associates. 1992. Geotechnical Investigation Lower Crystal Springs Dam Bridge; San Mateo County, CA. Prepared by Wahler & Associates. January 1992.

This Page Intentionally Left Blank



Down to Earth.
Down to Business.™